

FUNDAMENTALS OF MAGNETICS DESIGN: INDUCTORS AND TRANSFORMERS

Thursday September 15, 2011

Arthur Williams
Chief Scientist
Telebyte Inc.

NOTE:

This presentation is introductory and does not present all of the different magnetic materials, their properties, vendors, core geometries, sizes, mounting hardware etc. However an extensive list of references is provided at end of the presentation for further exploration.

There are over 100 slides so I will go quickly. Please reserve all questions for the end. This presentation will be posted on the IEEE Website in the next few days.

<http://www.ieee.li/cas/index.htm>

SOME BASIC DEFINITIONS

- Permeability- Figure of merit of a particular magnetic material representing the ease of producing a magnetic flux for a given input

$$\mu = \frac{B}{H} \quad (\text{Equation 1})$$

- *B is the magnetic flux density and H is the magnetizing force that generated the flux.*
- In the CGS system B is measured in Gauss which is Lines of Magnetic Flux per Square Centimeter.
- In the SI system the unit of measurement of B is the Tesla which is Webers per Square Meter.
- A Tesla is equal to 10,000 Gauss.

- H, the Magnetizing Force that produces the Flux, is measured in either Oersteds in the CGS system or Amps per Meter in the SI system
- The Oersted is defined as $1000/4\pi$ (≈ 79.5774715) amperes per meter so, the H-field strength inside a long solenoid wound with 79.58 turns per meter, of a wire carrying 1 Ampere will be approximately 1 Oersted.
- Permeability μ is dimensionless and can be considered a figure of merit of a particular magnetic material, since it represents the ease of producing a field of magnetic flux for a given input. The permeability of air or that of a vacuum is 1 (an air-core inductor for example).
- Magnetizing force is caused by current flowing through turns of wire; so H in Oersteds can be determined from ampere-turns by

$$H = \frac{4\pi NI}{10 \text{ mL}} \quad (\text{Equation 2})$$

where N is the number of turns, I is the current in amperes, and mL is the mean length of the magnetic path in centimeters.

- The inductance of a coil is directly proportional to the number of flux linkages per unit current. The **total** flux is found from

$$\phi = BA = \mu HA = \frac{4\pi NI\mu A}{10 \text{ mL}} \quad (\text{Equation 3})$$

where A is the cross-sectional area in square centimeters and ml is the mean path length in centimeters.

- The inductance proportionality may then be given by

$$L \propto \frac{4\pi NI\mu A}{10 \text{ mL}} \frac{N}{I} \quad (\text{Equation 4})$$

or directly in henrys

$$L = \frac{4\pi N^2 \mu A}{\text{mL}} 10^{-9} \quad (\text{Equation 5})$$

- Observe that the ***inductance of a coil is directly proportional to the permeability of the core material.*** If an iron core is inserted into an air-core inductor, ***the inductance will increase in direct proportion to the core's permeability.*** The inductance is also proportional to N^2 .

- All the previous design equations make the assumption that the magnetic path is **uniform** and closed with negligible leakage flux in the surrounding air such as would occur with a single-layer toroidal coil structure.
- A toroid is the *most ideal* core structure and has the least leakage flux. However, the assumption of no leakage flux is really never completely valid, so some deviations from the theory can be expected.

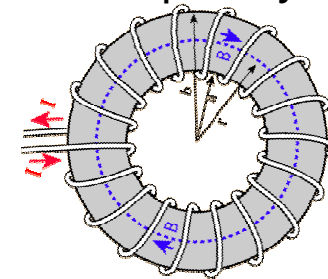

Fig 1

- The induced voltage of an inductor can be related to the flux density by

$$E_{\text{rms}} = 4.44BNfA \times 10^{-8} \quad (\text{Equation 6})$$

B is the maximum flux density in Gauss, N is the number of turns, f is the frequency in hertz, and A is the cross-sectional area of the core in square centimeters. This important equation is derived from Faraday's law.

- Using this equation and solving for B one can determine if the operating conditions result in core saturation using BH curves given for the magnetic material.

THE BH CURVE

A plot of B vs. H (BH Curve) appears as follows. Let us start at point A and increase the magnetizing force to obtain point B. Decreasing the magnetizing force will pass through point C and then D and then E as the magnetizing force becomes negative. An increasing magnetizing force, again in the positive direction, will travel to B through point F.

The enclosed area formed by the curve is called a ***hysteresis loop*** and results from the energy required to reverse the magnetic molecules of the core.

The magnitude of H between points D and A is called ***coercive force*** and is the amount of H necessary to reduce the residual magnetism in the core to zero.

Fig 2

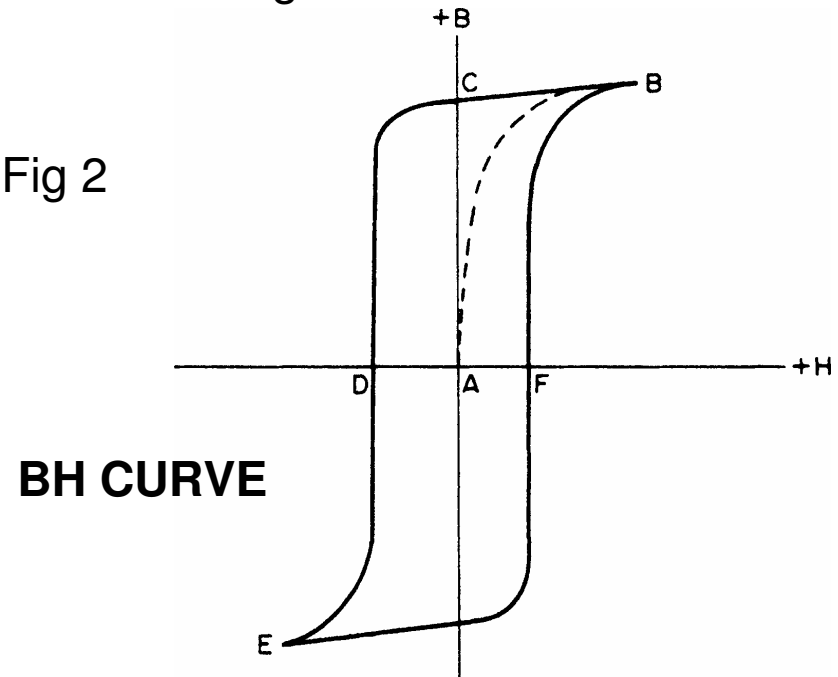

The amount of flux density remaining is called the **remanence (residual magnetism)** of the magnetic material. '*Soft*' magnetic materials, used in the manufacture of coil and transformer cores, have a very small remanence and '*hard*' magnetic materials, used in the manufacture of permanent magnets, have a very high remanence.

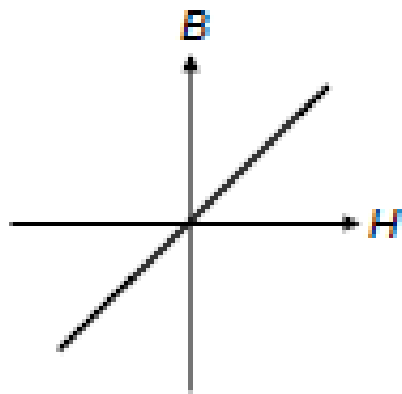

a) ideal BH loop

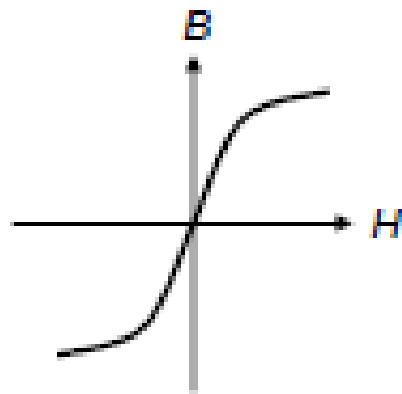

b) with saturation

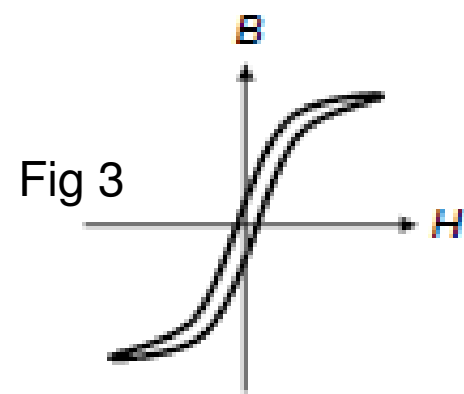

c) with saturation and low iron loss

- The magnetic materials discussed in this presentation and the operating points of relatively low level AC excitation and little or no DC bias results in very little hysteresis. The emphasis of this part of the presentation is to obtain High Q inductors at nominal AC excitation. The theory and design of high power inductors is outside the context of this presentation.

- Permeability μ is defined as the ratio B/H and can be obtained from the slope of the BH curve.
- With low-level AC signals, the region of interest is restricted to a relatively narrow range. We can then assume that the permeability is determined by the *derivative* of the curve at the origin. The derivative of a B/H curve is sometimes called *incremental permeability*.
- BH curves are normally shown for one quadrant for simplicity. Note that magnetic materials' 1 through 9 have different permeabilities (slopes at the origin) and some saturate (flatten) at a lower H than others.

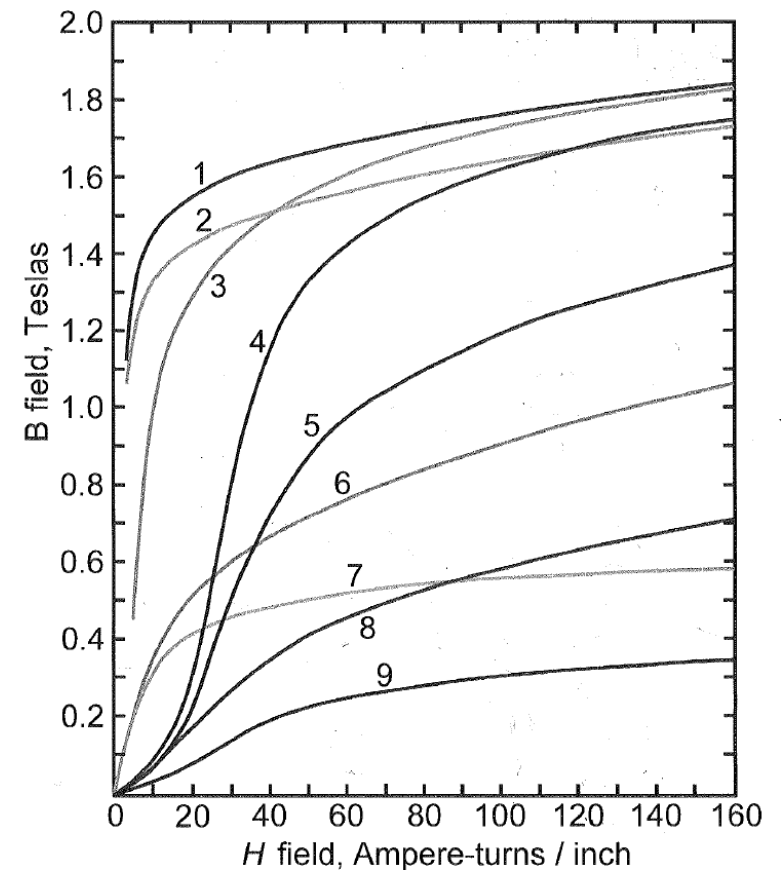

Magnetics Inc.

Fig 4

- If a DC bias or offset is introduced, the *quiescent point* will move from the origin to a point farther out on the curve.
- Since the curve tends to flatten out with higher values of H , the incremental permeability will decrease, which reduces the inductance. This effect is known as *saturation* and can also occur without a DC bias for large AC signals.
- Severe waveform distortion usually accompanies saturation. The B/H curve for an air core is a straight line through the origin. The permeability is unity, and no saturation can occur.
- The following figure shows a BH curve of a Ferrite core and the associated μ which is the *slope* or *derivative* of the BH curve.

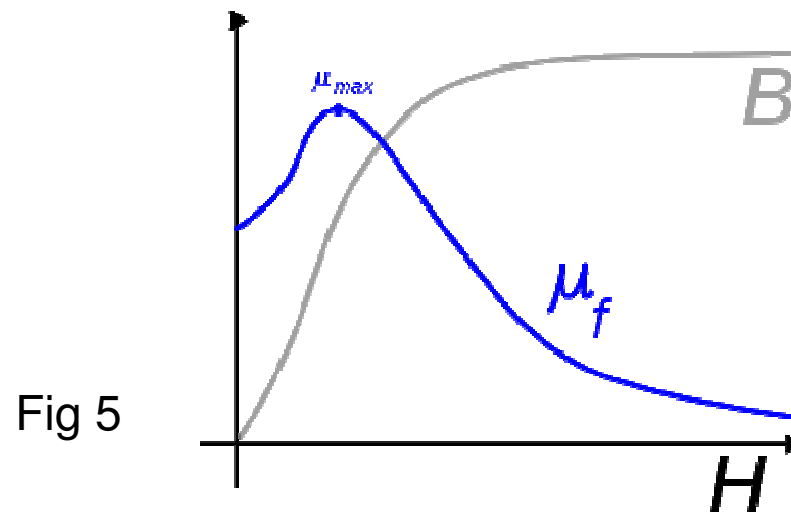

Maximum Permeability

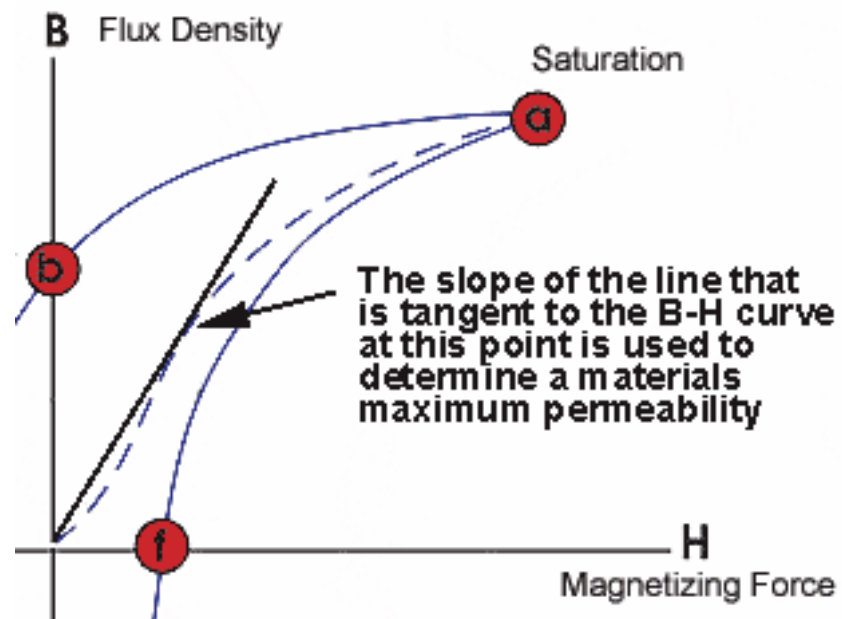
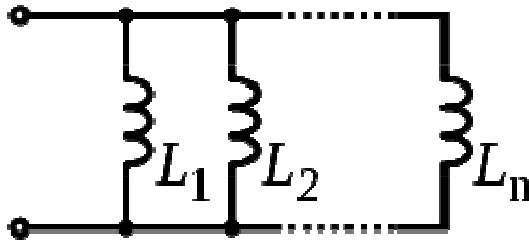

Fig 6

PROPERTIES OF INDUCTORS

- It is well known that inductors in parallel combine like resistors in parallel



$$\frac{1}{L_{eq}} = \frac{1}{L_1} + \frac{1}{L_2} + \dots + \frac{1}{L_n}$$

(Equation 7)

- Inductors in series combine like resistors in series

- $L_T = L_1 + L_2 + \dots + L_n$



Fig 7

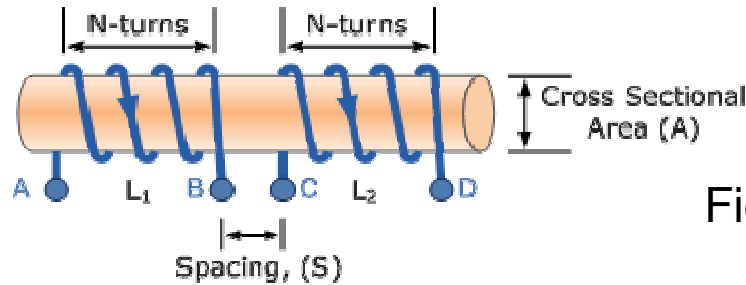

Fig 8

- Two coil windings that share the same magnetic core have a *Mutual Inductance* since the change in current in one inductor would cause a flux that induces a voltage in another nearby inductor. (this is also the mechanism of transformers).
- The mutual inductance, M , is also a measure of the coupling between two inductors since not all lines of flux produced by one of the inductors links with the other (called Leakage Inductance).
- So the two inductances above would add as :

$$L_T = L_1 + L_2 + 2M \quad (\text{Equation 8})$$

$$M = k \sqrt{L_1 L_2} \quad (\text{Equation 9})$$

where k is the Coefficient of Coupling of flux between the two coils and ranges from 0 to 1 (For 1 all lines of flux couple)

- **Note that if $L_1 = L_2 = L$ and $k = 1$, then $L_T = 4xL$**

INDUCTOR LOSSES

- The Figure of Merit (quality of the inductor) is given by the Inductors' Q , a dimensionless number. It is defined by:

$$Q = \frac{\omega L}{R_{dc} + R_{ac} + R_d} \quad (\text{Equation 10})$$

where $\omega = 2\pi F$

R_{dc} = DC Resistance (copper loss)

R_{ac} = Core Loss and Skin Effect

R_d = Dielectric Loss

- DC Resistance also known as DCR or copper loss consists strictly of the DC winding resistance and is determined by the wire size and total length of wire required as well as the specific resistivity of copper.
- The Core Loss is composed mostly of losses due to *eddy currents* and *hysteresis*. Eddy currents are induced in the core material by changing magnetic fields. These circulating currents produce losses that are proportional to the square of the inducing frequency.
- Hysteresis is represented by the enclosed area within a BH curve and results from the energy required to reverse the magnetic domains in the core material. These core losses increase in direct proportion to frequency, since each cycle traverses the hysteresis loop.
- Skin Effect increases the wire resistance above approximately 50 kHz because the current tends to travel on the *surface* of a conductor rather than through the cross section. This reduces the current-carrying cross-sectional area.

- To reduce skin effect, *litz wire* is commonly used. Litz wire consists of many braided strands of insulated conductors so that a *larger effective surface area* is available in comparison with a single solid conductor of the equivalent cross section.

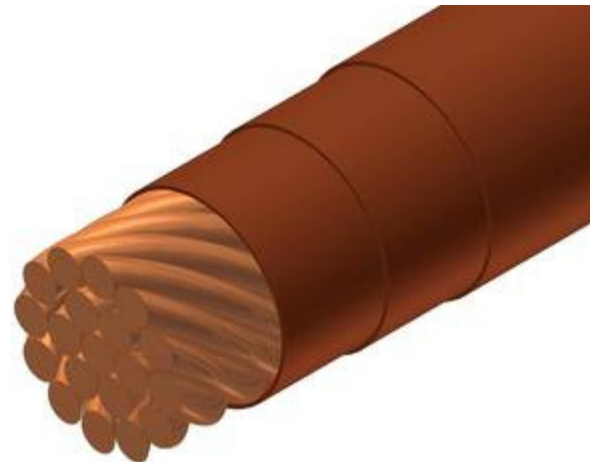

Fig 9

- Above 1 or 2 MHz, solid wire can again be used.

- The Dielectric Losses are important at higher frequencies and are determined by the power factor of the distributed capacity. Distributed (parasitic) capacity is caused by the capacitance of the coil turns with the wire insulation acting as a dielectric.
- Keep distributed capacity small
- Use wire insulation with good dielectric properties to minimize dielectric losses. Normally the insulation is Polyurethane which is solderable. However for extremely low dielectric losses Teflon wire is available although this insulation is much more difficult to remove.
- Ohms/Henry A figure of merit of the efficiency of a coil at *low frequencies* is the ratio of ohms per henry (Ω/H), where the ohms correspond to R_{dc} , i.e., the copper losses. For a given coil structure and permeability, the ratio Ω/H is a constant independent of the total number of turns, provided that the winding cross-sectional area is kept constant. For example if you double the number of turns you get 4x the Inductance but it takes twice as many turns and half the wire diameter so the Ω/H stays the same.

DISTRIBUTED CAPACITANCE

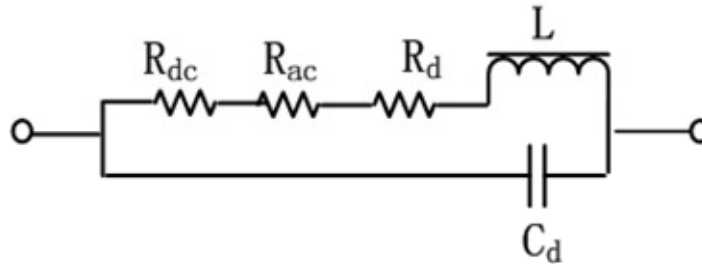

Fig 10

- The equivalent circuit of an inductor is shown above. R_{dc} is the DC resistance, R_{ac} is the core loss and skin effect and R_d is the dielectric loss. The dielectric losses occur mainly due to the losses in the wire insulation. All these factors affect inductor Q.
- The capacitance C_d is the turn-to-turn and turn-to-core distributed capacitance. The result is that the inductor has a self-resonant frequency (SRF) where it appears like a parallel resonant circuit. Above this frequency the inductor behaves like a capacitor.
- The effect of the SRF is to increase the *effective inductance* so it appears higher than the true (low frequency) inductance. For example if a 10mH inductor has 100pF of distributed capacitance, the actual resonating capacitance *needed* for a particular frequency would be 100pF *lower* due to the distributed capacitance. Therefore the effective inductance appears as if it were *higher* than 10mH.

- The effective inductance is given by

$$L_{\text{eff}} = \frac{L_T}{1 - \left(\frac{f}{f_r}\right)^2} \quad (\text{Equation 11})$$

where L_T is the true (low-frequency) inductance, f is the frequency of interest, and f_r is the inductor's self-resonant frequency. As f approaches f_r , the value of L_{eff} increases quite dramatically and will become infinite at self-resonance.

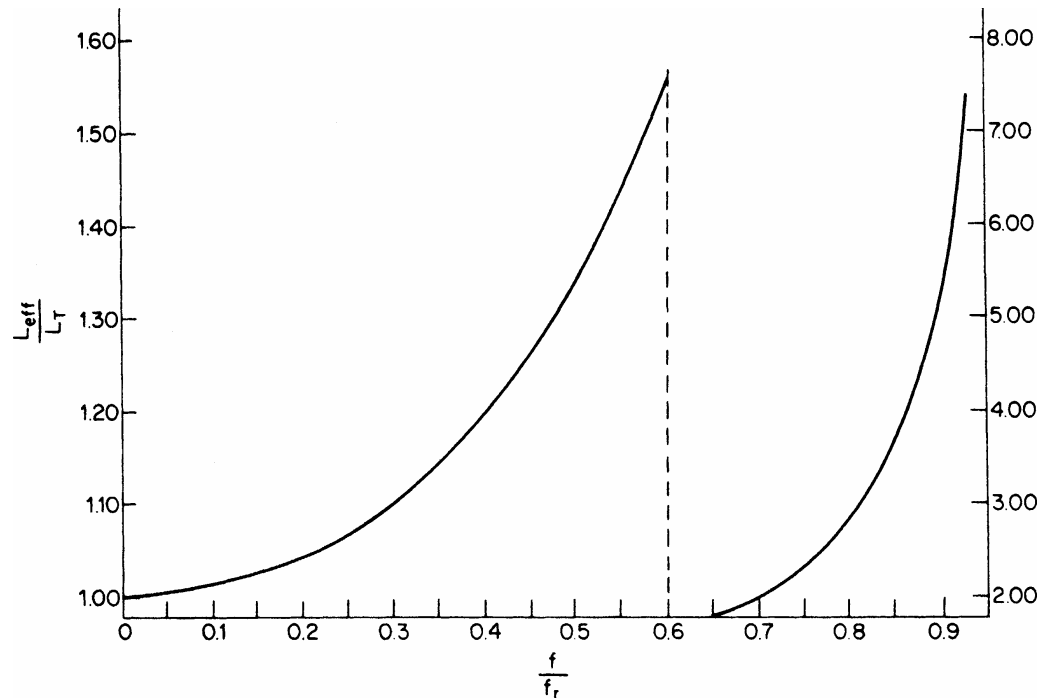

Fig 11

EFFECT OF AN AIR GAP

- If an ideal toroidal core has a narrow air gap introduced, the magnetic flux will decrease and the permeability will be reduced. The resulting effective permeability can be found from

$$\mu_e = \frac{\mu_i}{1 + \mu_i \left(\frac{g}{mL} \right)} \quad (\text{Equation 12})$$

where μ_i is the initial permeability of the core and g/mL is the *ratio* of gap to length of the magnetic path. *This equation applies to closed magnetic structures of any shape if the initial permeability is high and the gap ratio small.*

- The effect of an air gap is to reduce the permeability and make the coil's characteristics *less dependent* upon the initial permeability of the core material. A gap will prevent saturation with large AC signals or DC bias and allow tighter control of inductance. However, lower permeability due to the gap requires more turns resulting in more copper losses, so a suitable compromise is required.

Gapped Magnetic Structures

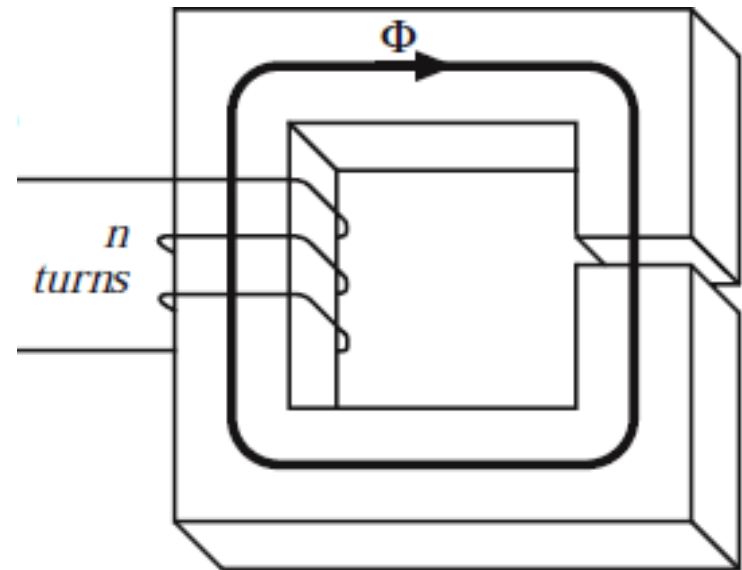
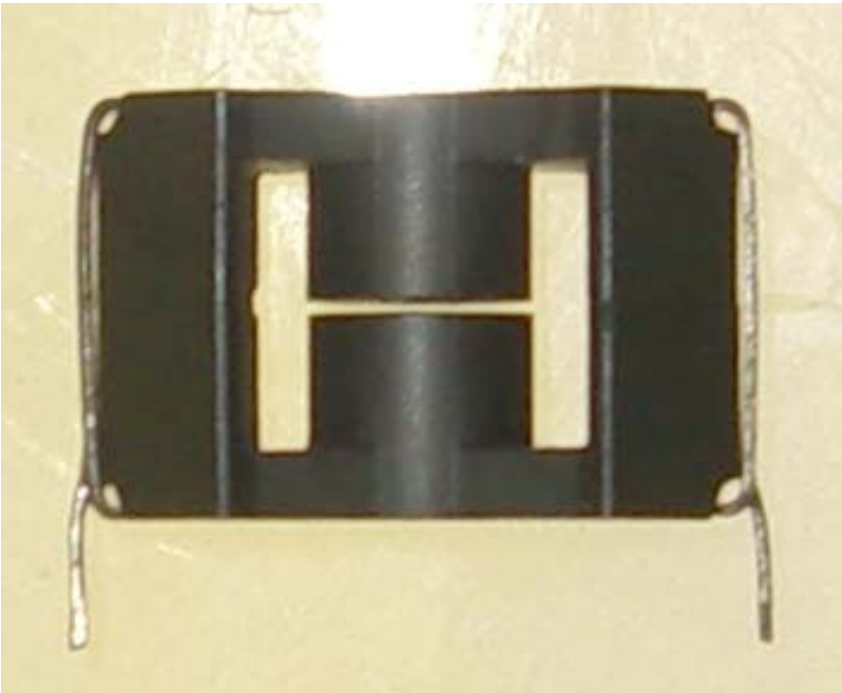

Fig 12

- The following diagram illustrates how an air gap can greatly linearize a BH curve at the expense of reducing permeability.

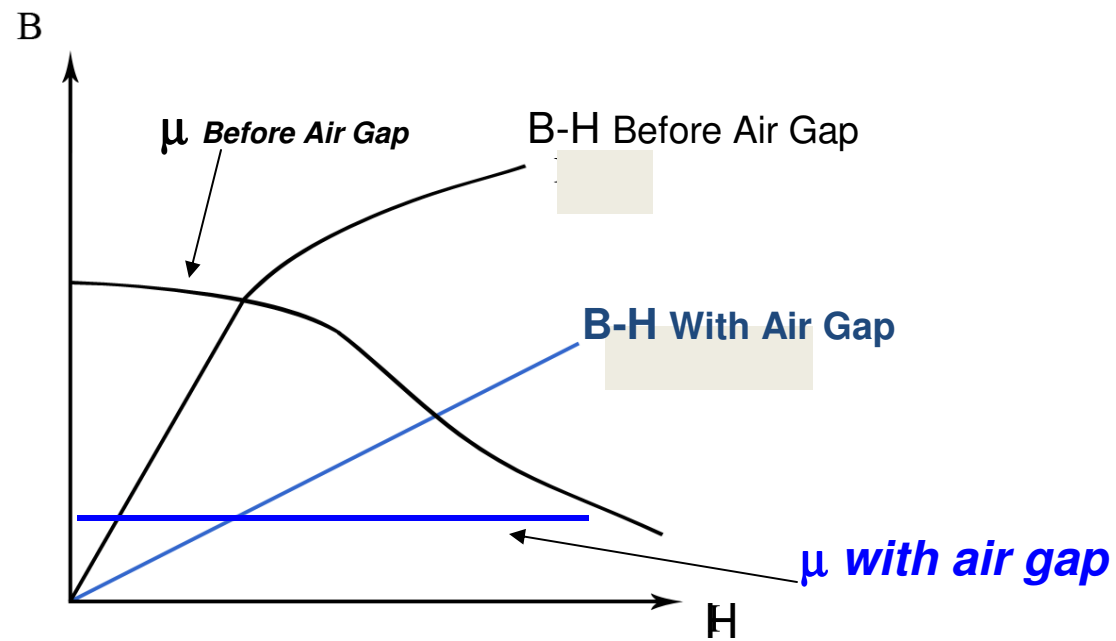

Fig 13

WIRE PROPERTIES

- The standard method used to express wire size is the American Wire Gauge (AWG) system.
- *As the wire size numerically decreases, the diameter increases.*
The ratio of the diameter of one size to the next larger size is 1.1229.
- It is the ratio of *areas* that is of the most interest as that determines the density of the turns (number of turns) and the resistance.
- The ratio of cross-sectional areas of adjacent wire sizes corresponds to the square of the diameter, or 1.261. Therefore, for an available cross-sectional winding area, *reducing* the wire by one size permits 1.261 times as many turns. **(Reducing a wire size means going to a smaller wire diameter or a larger AWG number.)**
- Two wire sizes correspond to a factor of 1.261^2 , or 1.59
- Three wire sizes represents a ratio of areas of 1.261^3 or 2:1 which permits twice as many turns.
- Ten wire sizes represent a ratio of areas of 1.261^{10} or 10:1.

<u>No of Wire Sizes</u>	<u>Ratio of Areas</u>
1	1.261
2	1.59
3	2.00
10	10.0

A useful rule of thumb is that 40 AWG wire has a resistance of approximately $1\ \Omega$ per foot.

To find the resistance of 1,000 feet 26AWG you can use the following shortcuts:

40 AWG = $1,000\ \Omega$ per 1,000 feet

30 AWG = $100\ \Omega$ per 1,000 feet

20 AWG = $10\ \Omega$ per 1,000 feet

23 AWG = $20\ \Omega$ per 1,000 feet

26 AWG = $40\ \Omega$ per 1,000 feet

Table 1

Wire Chart—Round Heavy Film Insulated Solid Copper

AWG	Diameter over Bare, in			Insulation Additions		Diameter over Insulation		Weight			Resistance at 20°C (68°F)			Turns		
	Minimum	Nominal	Maximum	Minimum	Maximum	Minimum	Maximum	Pounds per 1000 Feet	Feet per pound	Pounds per Cubic Inch	Ohms per 1000 Feet	Ohms per Pound	Ohms per Cubic Inch	Per Linear Inch	Per Square Inch	
																AWG
19	0.0355	0.0359	0.0361	0.0025	0.0030	0.0380	0.0391	3.99	251	0.223	8.05	2.02	0.450	25.9	671	19
20	0.0317	0.0320	0.0322	0.0023	0.0029	0.0340	0.0351	3.18	314	0.221	10.1	3.18	0.703	28.9	835	20
21	0.0282	0.0285	0.0286	0.0022	0.0028	0.0302	0.0314	2.53	395	0.219	12.8	5.06	1.11	32.3	1,043	21
22	0.0250	0.0253	0.0254	0.0021	0.0027	0.0271	0.0281	2.00	500	0.217	16.2	8.10	1.76	36.1	1,303	22
23	0.0224	0.0226	0.0227	0.0020	0.0026	0.0244	0.0253	1.60	625	0.215	20.3	12.7	2.73	40.2	1,616	23
24	0.0199	0.0201	0.0202	0.0019	0.0025	0.0218	0.0227	1.26	794	0.211	25.7	20.4	4.30	44.8	2,007	24
25	0.0177	0.0179	0.0180	0.0018	0.0023	0.0195	0.0203	1.00	1,000	0.210	32.4	32.4	6.80	50.1	2,510	25
26	0.0157	0.0159	0.0160	0.0017	0.0022	0.0174	0.0182	0.794	1,259	0.208	41.0	51.6	10.7	56.0	3,136	26
27	0.0141	0.0142	0.0143	0.0016	0.0021	0.0157	0.0164	0.634	1,577	0.205	51.4	81.1	16.6	62.3	3,831	27
28	0.0125	0.0126	0.0127	0.0016	0.0020	0.0141	0.0147	0.502	1,992	0.202	65.3	130	26.3	69.4	4,816	28
29	0.0112	0.0113	0.0114	0.0015	0.0019	0.0127	0.0133	0.405	2,469	0.200	81.2	200	40.0	76.9	5,914	29
30	0.0099	0.0100	0.0101	0.0014	0.0018	0.0113	0.0119	0.318	3,145	0.197	104	327	64.4	86.2	7,430	30
31	0.0088	0.0089	0.0090	0.0013	0.0018	0.0101	0.0108	0.253	4,000	0.193	131	520	100	96	9,200	31
32	0.0079	0.0080	0.0081	0.0012	0.0017	0.0091	0.0098	0.205	4,900	0.191	162	790	151	106	11,200	32
33	0.0070	0.0071	0.0072	0.0011	0.0016	0.0081	0.0088	0.162	6,200	0.189	206	1,270	240	118	13,900	33
34	0.0062	0.0063	0.0064	0.0010	0.0014	0.0072	0.0078	0.127	7,900	0.189	261	2,060	388	133	17,700	34
35	0.0055	0.0056	0.0057	0.0009	0.0013	0.0064	0.0070	0.101	9,900	0.187	331	3,280	613	149	22,200	35
36	0.0049	0.0050	0.0051	0.0008	0.0012	0.0057	0.0063	0.0805	12,400	0.186	415	5,150	959	167	27,900	36
37	0.0044	0.0045	0.0046	0.0008	0.0011	0.0052	0.0057	0.0655	15,300	0.184	512	7,800	1,438	183	33,500	37
38	0.0039	0.0040	0.0041	0.0007	0.0010	0.0046	0.0051	0.0518	19,300	0.183	648	12,500	2,289	206	42,400	38
39	0.0034	0.0035	0.0036	0.0006	0.0009	0.0040	0.0045	0.0397	25,200	0.183	847	21,300	3,904	235	52,200	39
40	0.0030	0.0031	0.0032	0.0006	0.0008	0.0036	0.0040	0.0312	32,100	0.183	1,080	34,600	6,335	263	69,200	40
41	0.0027	0.0028	0.0029	0.0005	0.0007	0.0032	0.0036	0.0254	39,400	0.183	1,320	52,000	9,510	294	86,400	41
42	0.0024	0.0025	0.0026	0.0004	0.0006	0.0028	0.0032	0.0203	49,300	0.182	1,660	81,800	14,883	328	107,600	42

The convention for specifying litz wire is number of strands/wire size. For example, using this chart, a litz equivalent to No. 31 solid is 20 strands of No. 44, or 20/44. In general a large number of strands is desirable for more effective surface area.

Table 2

Litz Wire Equivalent Chart

Solid Equivalent	Size per Strand										
	34	35	36	37	38	39	40	41	42	43	44
15	80	100									
16	64	80	100								
17	50	64	80	100							
18	40	50	64	80	100						
19	32	40	50	64	80	100					
20	25	32	40	50	64	80	100				
21	20	25	32	40	50	64	80	100			
22	16	20	25	32	40	50	64	80	100		
23	12	16	20	25	32	40	50	64	80	100	
24	10	12	16	20	25	32	40	50	64	80	100
25	8	10	12	16	20	25	32	40	50	64	80
26	6	8	10	12	16	20	25	32	40	50	64
27	5	6	8	10	12	16	20	25	32	40	50
28	4	5	6	8	10	12	16	20	25	32	40
29		4	5	6	8	10	12	16	20	25	32
30			4	5	6	8	10	12	16	20	25
31				4	5	6	8	10	12	16	20
32					4	5	6	8	10	12	16
33						4	5	6	8	10	12
34							4	5	6	8	10
35								4	5	6	8
36									4	5	6
37										4	5
38											4

- The temperature coefficient of resistance for copper is 0.393% per degree Celsius. The DC resistance of a winding at a particular temperature can be found by

$$R_{t_1} = R_t [1 + 0.00393(t_1 - t)] \quad (\text{Equation 13})$$

where t is the initial temperature and t_1 is the final temperature, both in degrees Celsius.

- This relationship can be useful for measuring temperature rise inside a transformer or power inductor. First you measure the DC resistance at room temperature (unpowered) and then after the component conducts current for a period of time (quickly after disconnecting it from the circuit so it doesn't cool). Solving for $(t_1 - t)$ will give you the temperature rise.
- The maximum allowable temperature for most wire insulation is about 130°C.

COMPUTING TURNS

- To calculate the number of turns for a required inductance for a given core, the inductance factor for that coil structure must be used.
- This factor is generally called A_L and is the nominal inductance per 100 or 1,000 turns.
- Since inductance is proportional to the number of turns squared, the required number of turns N for an inductance L is given by:

For $A_L = \text{mH}/1,000$ Turns
$$N = 10^3 \sqrt{\frac{L}{A_L}} \quad (\text{Equation 14})$$

For $A_L = \mu\text{H}/100$ Turns
$$N = 10^2 \sqrt{\frac{L}{A_L}}$$

For $A_L = \text{nH}/\text{Turn}$
$$N = \sqrt{\frac{L}{A_L}}$$

L and A_L must be in identical units in all cases.

- After the required number of turns is computed for a given A_L , a wire size must be chosen. For each winding structure an associated table can be created to indicate the maximum number of turns for each wire size. Sometimes the wire size needs to be reduced one or two sizes where the bobbin is a split bobbin (having one or more barriers).
- A wire size is then be chosen to result in the maximum utilization of the available winding cross-sectional area, in other words the largest wire the structure can accommodate (there are exceptions to this for higher frequency coils).
- Coil winding methods are very diverse since the winding techniques depend upon the actual coil structure, the operating frequency range, etc. Coil winding techniques will be discussed for each core structure.

CORE MATERIALS AND STRUCTURES

MPP TOROIDAL COILS

- MPP or Moly permalloy Powder cores are manufactured by pulverizing a magnetic alloy consisting of approximately 2% molybdenum, 81% nickel, and 17% iron into a fine powder, insulating the powder with a ceramic binder to form a uniformly distributed air gap, and then compressing it into a toroidal core .

BENEFITS

- Extremely stable with temperature and time
- Useful below a few hundred Kilohertz
- Low core losses over a wide range of available permeabilities
- Inductance remains stable with large changes in flux density, frequency, temperature, and DC magnetization due to high resistivity, low hysteresis, and low eddy-current losses.
- Categorized according to size, permeability, and temperature stability.
- Larger cores offer higher Q_s , since flux density is lower due to the larger cross-sectional area, resulting in lower core losses, and the larger window area reduces the copper losses.
- Toroidal geometry, enclosed magnetic field, very low leakage

NEGATIVES

- Relatively costly
- A_L typical tolerances of +/-8% requiring final coil adjustment by adding or removing turns by hand or core grading
- Requires special machinery for winding if large number of turns needed
- Not suitable for mass winding as only one coil at a time can be wound per machine

CORE SIZES AND PERMEABILITIES

- Cores can range in size from an OD of 0.140 to 5.218 inches. The dimensions for typical toroids are shown in table 3.
- Available core permeabilities range from 14 to 550.
- Lower permeabilities are more suitable for use at the higher frequencies, since the core losses are lower.

Table 3

Toroidal Core Dimensions

OD, in	ID, in	HT, in	Cross Section, cm ²	Path Length, cm	Window Area, circular mils	Wound OD, in	Coil HT, in
0.310	0.156	0.125	0.0615	1.787	18,200	1 ¹ / ₃₂	3 ³ / ₁₆
0.500	0.300	0.187	0.114	3.12	75,600	1 ⁹ / ₃₂	9 ⁹ / ₃₂
0.650	0.400	0.250	0.192	4.11	140,600	2 ⁵ / ₃₂	3 ³ / ₈
0.800	0.500	0.250	0.226	5.09	225,600	1	3 ³ / ₈
0.900	0.550	0.300	0.331	5.67	277,700	1 ³ / ₃₂	1 ¹ / ₂
1.060	0.580	0.440	0.654	6.35	308,000	1 ¹ / ₄	5 ⁵ / ₈
1.350	0.920	0.350	0.454	8.95	788,500	1 ⁵ / ₈	5 ⁵ / ₈
1.570	0.950	0.570	1.072	9.84	842,700	1 ⁷ / ₈	7 ⁷ / ₈
2.000	1.250	0.530	1.250	12.73	1,484,000	2 ³ / ₈	1 ¹ / ₈

NOTE: Core dimensions are before finish.

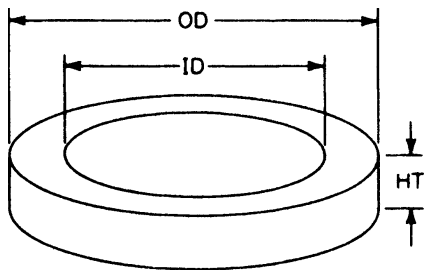

The following wire table assumes that the core window is approximately 50% utilized. Full window utilization is not possible, since a hole must be provided for a shuttle in the coil winding machine which applies the turns.

Wire Capacities of Standard Toroidal Cores
50% Utilization of Window Area

Table 4

Size	Core OD, in								
	0.310	0.500	0.650	0.800	0.900	1.060	1.350	1.570	2.000
25		75	148	189	257	284	750	930	1,735
26		95	186	238	323	357	946	1,172	2,180
27		119	235	300	406	450	1,190	1,470	2,750
28		150	295	377	513	567	1,500	1,860	3,470
29		190	375	475	646	714	1,890	2,350	4,365
30	59	238	472	605	814	925	2,390	2,960	5,550
31	74	300	595	765	1,025	1,180	3,000	3,720	7,090
32	94	376	750	985	1,290	1,510	3,780	4,700	9,000
33	118	475	945	1,250	1,625	1,970	4,763	5,920	11,450
34	150	600	1,190	1,580	2,050	2,520	6,000	7,440	14,550
35	188	753	1,500	2,000	2,585	3,170	7,560	9,400	18,500
36	237	950	1,890	2,520	3,245	4,000	9,510	11,840	23,500
37	300	1,220	2,380	3,170	4,100	5,050	12,000	14,880	30,000
38	378	1,550	3,000	4,000	5,175	6,300	15,150	18,800	38,000
39	476	1,970	3,780	5,050	6,510	8,000	19,050	23,680	48,500
40	600	2,500	4,750	6,300	8,200	10,100	24,000	30,000	61,300
41	755								
42	950								
43	1,200								
44	1,510								
45	1,900								

- The following table lists the A_L (inductance per 1000 turns) and ohms per henry for MPP cores with a permeability of 125. For other permeabilities, the A_L is directly proportional to μ and the ohms per henry is inversely proportional to μ .
- The ohms per henry corresponds to the DC resistance factor when the core window is approximately 50% utilized. Full window utilization is not possible, since a hole must be provided for a shuttle in the coil winding machine which applies the turns.

Table 5

Electrical Properties for $\mu = 125$ MPP Coils

OD, in	A_L , mH	Ω/H
0.310	52	900
0.500	56	480
0.650	72	160
0.800	68	220
0.900	90	150
1.060	157	110
1.350	79	80
1.570	168	45
2.000	152	30

- MPP cores are available in three categories of temperature stabilities: standard, stabilized, and linear (where linear is a subset of stabilized and intended to complement polystyrene capacitors when used in a resonant circuit).
- Stabilizing techniques are based on the addition of a small amount of special compensating alloys having curie points within the temperature range of operation. (The curie point is the temperature where the material becomes nonmagnetic.)
- As each curie point is passed, the particles act as distributed non-magnetic air gaps which can be used to compensate for permeability changes of the basic alloy, so as to maintain the inductance nearly constant.

- **DC Bias and AC Flux Density.** Under conditions of DC bias current, MPP cores may exhibit a reduction in permeability because of the effects of saturation.
- If the reduction in permeability and resulting inductance decrease is no more than about 30%, the turns can be increased to compensate for the effect of the bias. If the decrease in permeability is more than 30%, the inductance may further decrease faster than N^2 if turns are added. A larger core would then be required.
- As the AC flux density is increased, the permeability will rise initially and then fall. Core losses can be assumed to be relatively constant for flux densities below 200 G. For higher values, the Q may be adversely affected.

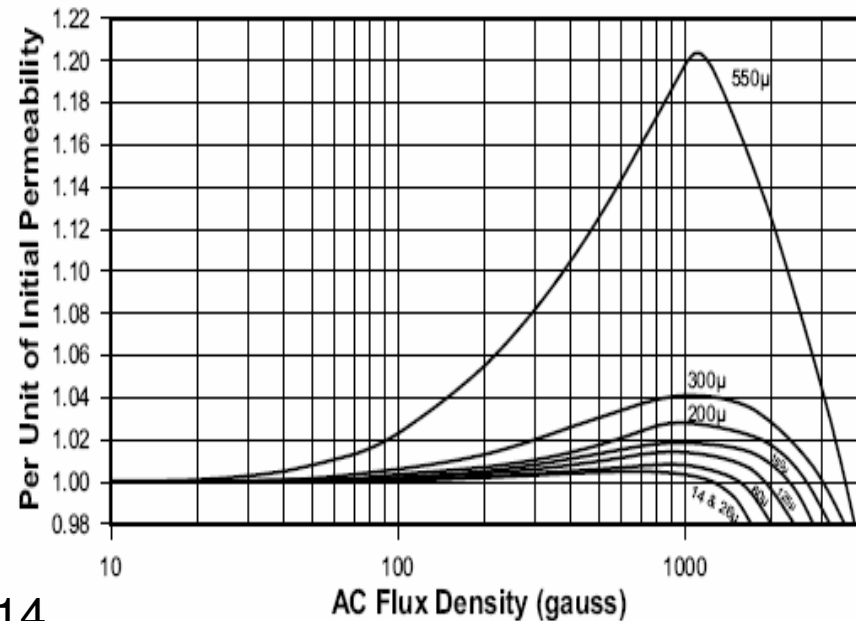
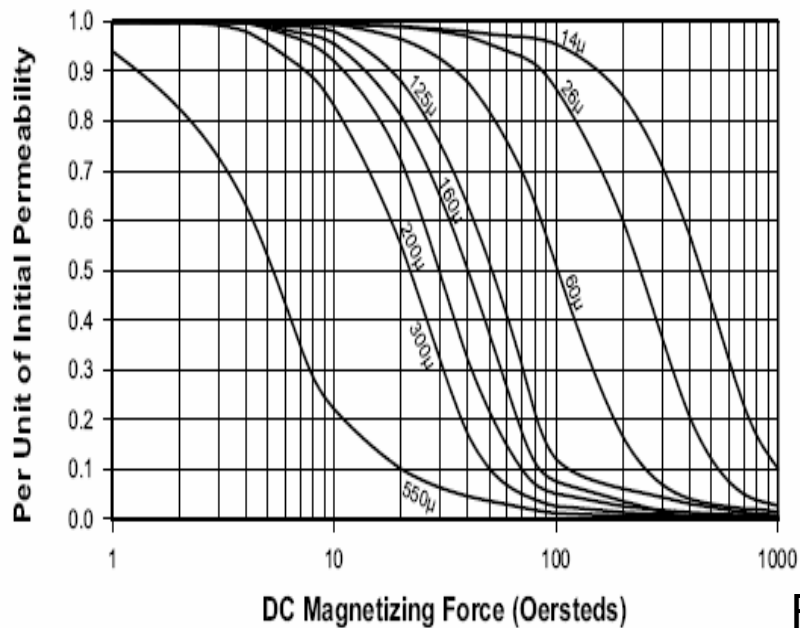
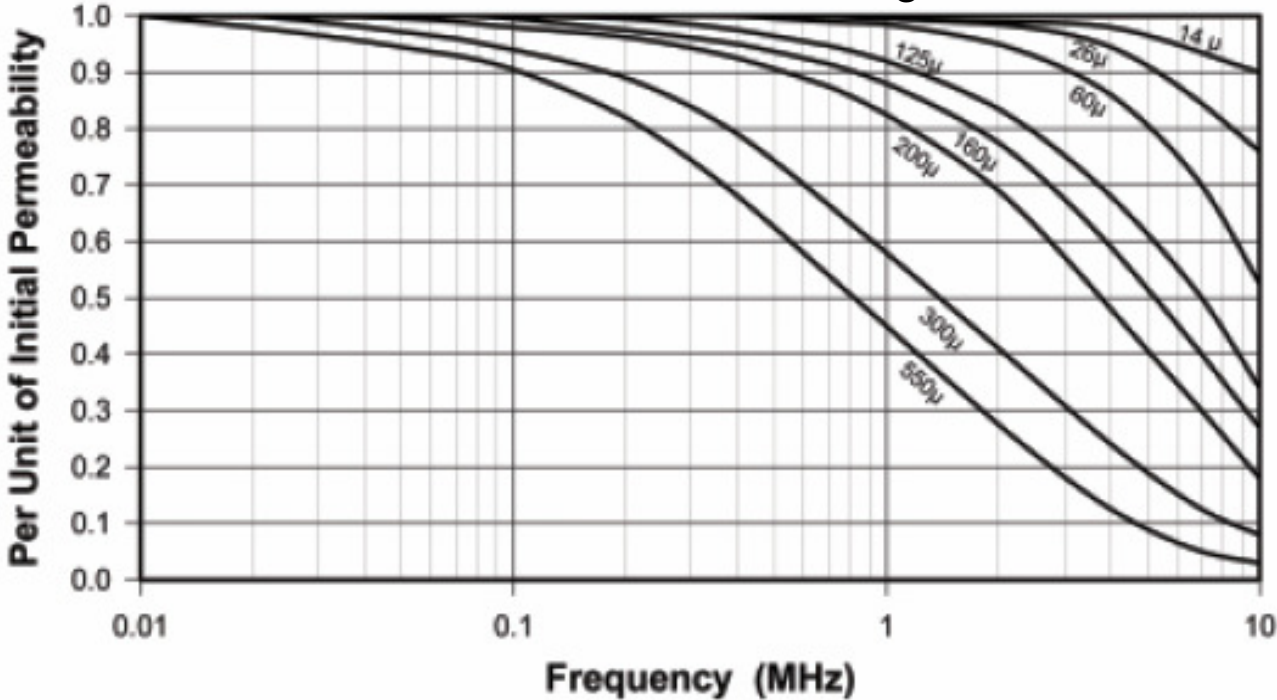

Fig 14

Courtesy Magnetics Inc

Permeability will also decrease with frequency as illustrated in the following graph:

Fig 15



COIL WINDING METHODS

- At low frequencies, the major losses are caused by the DC resistance of the winding. The objective then is to utilize the *maximum possible winding area* (use the largest possible wire size).
- Low frequencies are defined as frequencies below where the core loss starts to significantly reduce Q and well below the self-resonant frequency (SRF). The Q rises over this range almost linearly as frequency is increased. Distributed capacity is of little consequence.
- At medium frequencies where the Q curves start to round off, distributed capacitance should be reduced resulting in higher Qs and avoiding an increase in the effective inductance. If the SRF is at least 10 x the highest frequency of operation its usually not an issue.
- For high frequencies C_d becomes a major limiting factor so the winding method becomes even more critical.

TOROID WINDING MACHINE

Observe the “shuttle” that goes through the *center* of the toroid and transfers the wire from the shuttle to the core. The shuttle is previously loaded with wire. These machines are microprocessor controlled to count the turns and stop appropriately. *Only one coil can be wound at a time.*

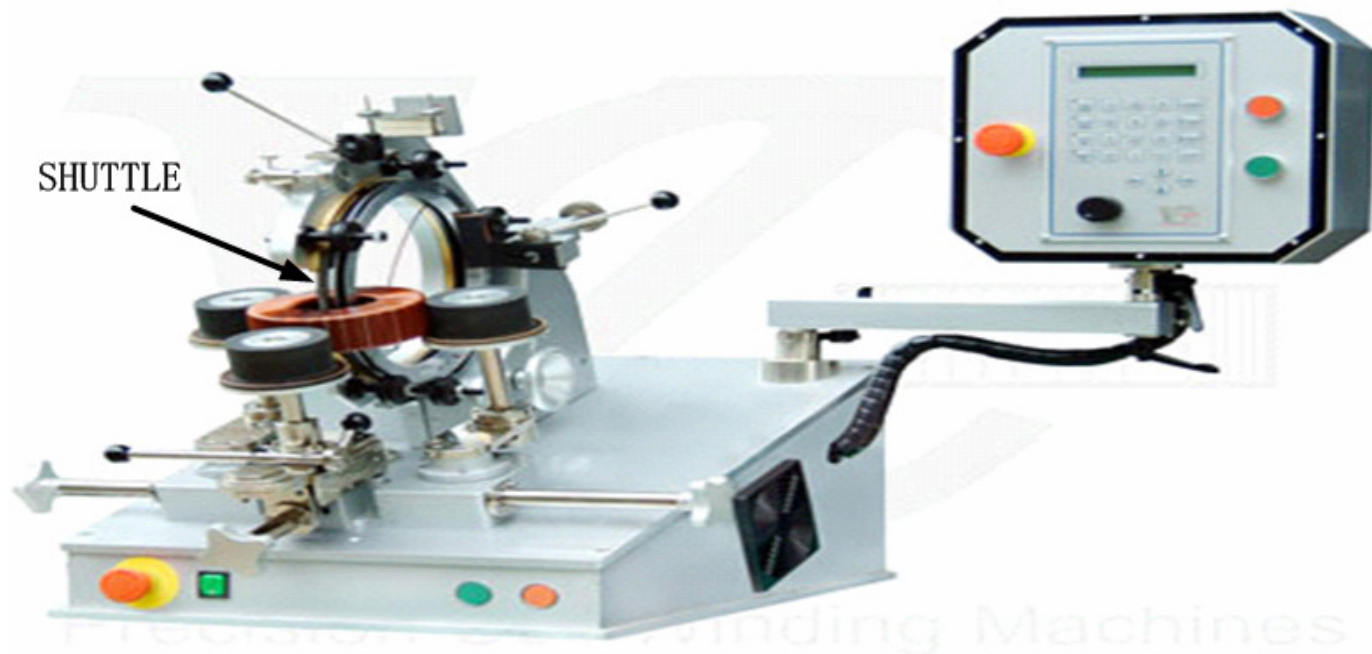

Fig 16

- The most efficient method of packing the most turns on a toroidal core is to rotate the core **continuously** in the same direction in the winding machine until maximum capacity is obtained. This technique is called the **360° method**. This will use up about 50% of the available center window. However it will result in the most distributed capacitance.
- By winding half the turns over a 180° sector of the core in a back-and-forth manner, and then repeating the remaining turns over the second half in the same fashion, the capacity will be reduced. This approach is called the **two-section** method and has lower distributed capacity.
- If the core is divided into *four* 90° quadrants and each sector is completed by itself in a back-and-forth winding fashion using one-fourth the total turns, a *four-section* coil will be obtained. A four-section winding structure has lower distributed capacity than the two-section method. The wire must be reduced one size for a four-section coil, resulting in more copper losses but less C_d .

- The most effective method to reduce C_d is called Progressive. It is an extension of the four section method except twelve 30° sections are filled up, one at a time each with $1/12$ the total number of turns. One may have to reduce the gauge by two wire sizes. A barrier is frequently used to separate the start and finish wires for further capacity reduction.
- Wrapping the *unwound* core with one or two layers of Mylar tape will reduce the capacitance even further. Teflon tape may be even more effective but usually is not required.
- Litz wire can significantly increase Q in the 50KHz to 2MHz range.

DESIGNING MPP COILS USING Q CURVES

- The following Q curves are based on empirical data measured using the 360° winding method. The range of distributed capacity C_d is typically between 10 and 25 pF for cores under 0.500 in OD, 25 to 50 pF for cores between 0.500 and 1.500 in OD, and 50 to 80 pF for cores over 1.500 in OD.

- Curves are provided for permeabilities of 60 and 125 and for a range of core sizes.

- For a given size and permeability, the Q curves all converge on the low-frequency portion of the curve, where the losses are determined almost entirely by the DC resistance of the winding. The Q in this converged region can be approximated by

$$Q = \frac{2\pi f}{\Omega / H} \quad (\text{Equation 15})$$

- As the frequency is increased, the curves start to diverge and reach a *maximum* at a frequency where the *copper and core losses equal each other*. Above this region the core losses start to dominate along with increased dielectric losses as self-resonance is approached so the Q will start to roll off quickly. It is always preferable to operate on the *rising* portion of Q curves, since the losses can be tightly controlled and the effective inductance remains relatively constant with frequency as you are well below self resonance.

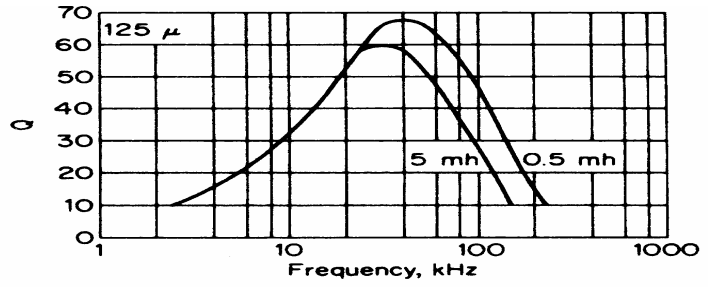
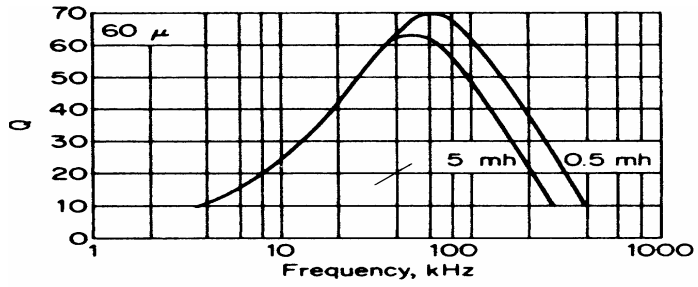

(a) OD = 0.310 in, ID = 0.156 in, HT = 0.125 in

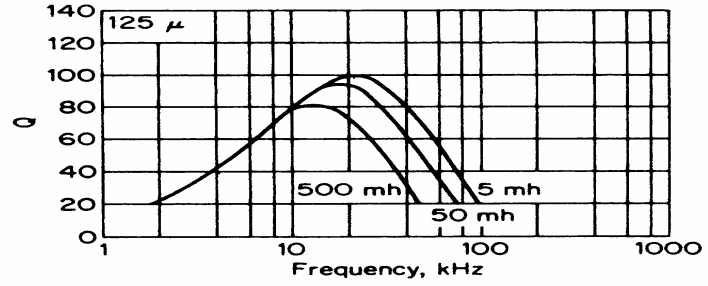
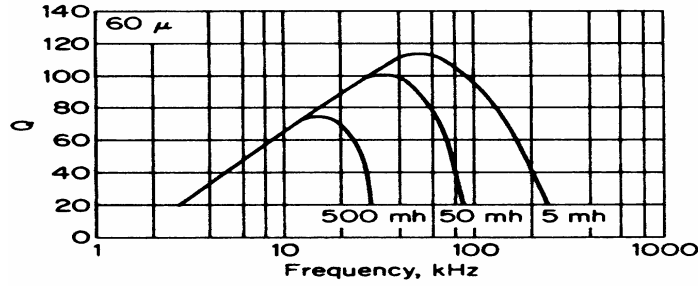

(b) OD = 0.500 in, ID = 0.300 in, HT = 0.187 in

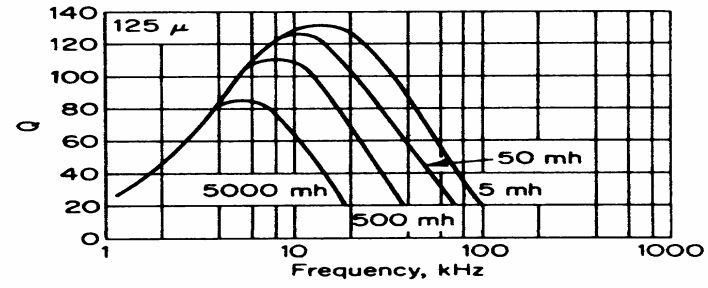
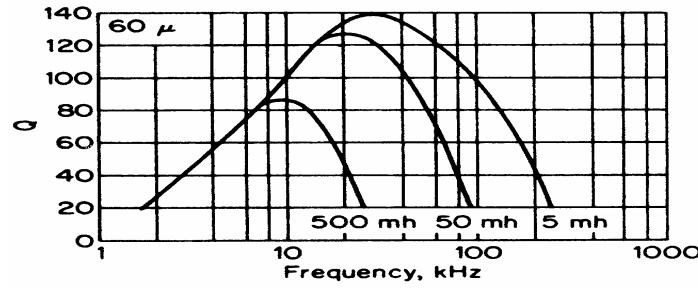

(c) OD = 0.650 in, ID = 0.400 in, HT = 0.250 in

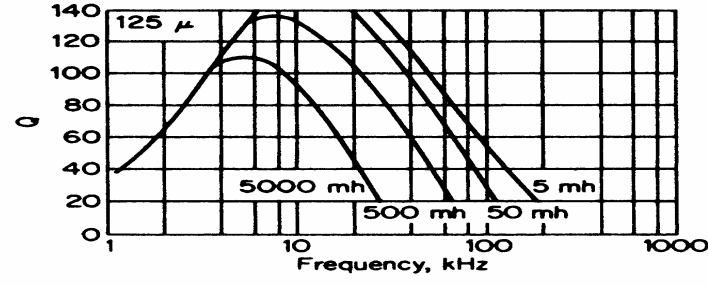
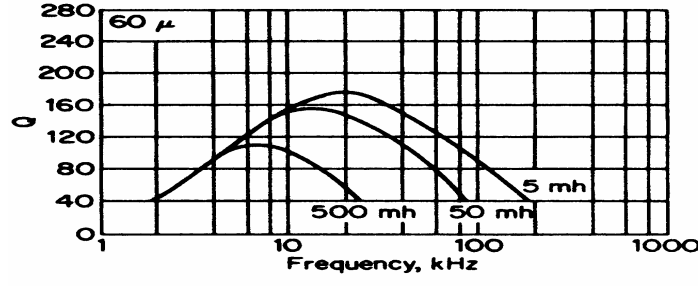

(d) OD = 0.800 in, ID = 0.500 in, HT = 0.250 in

Fig 17

Courtesy Magnetics Inc

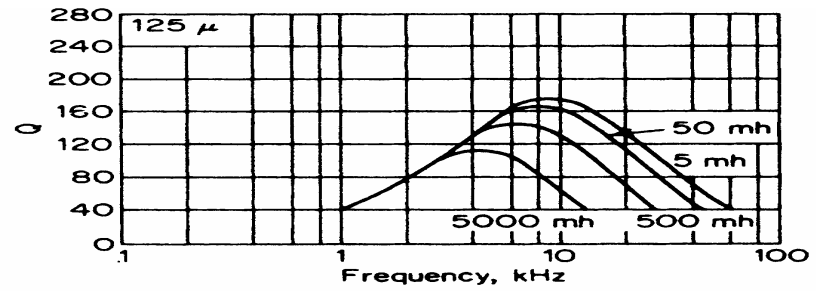
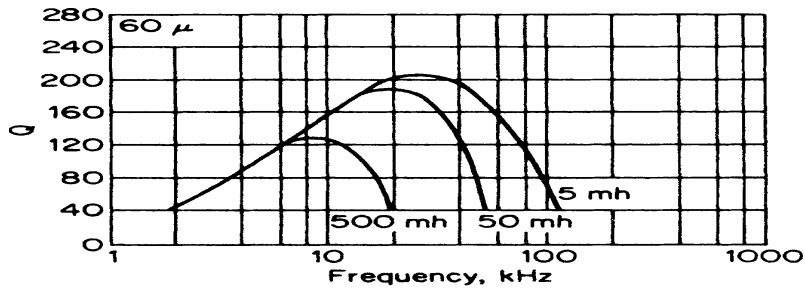

(e) OD = 0.900 in, ID = 0.550 in, HT = 0.300 in

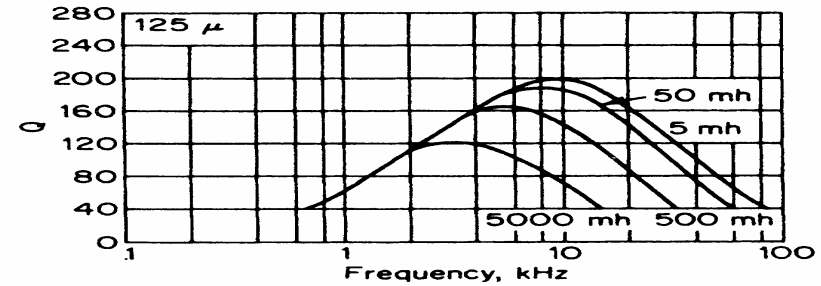
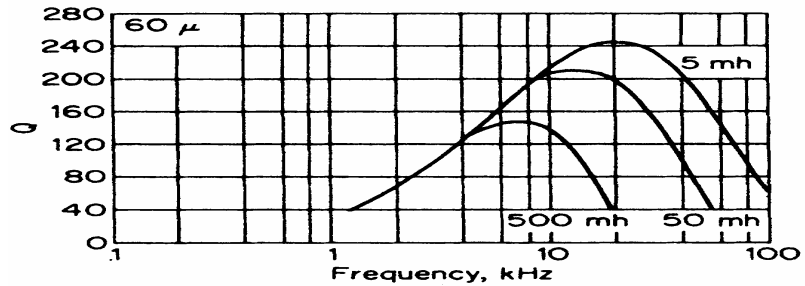

(f) OD = 1.060 in, ID = 0.580 in, HT = 0.440 in

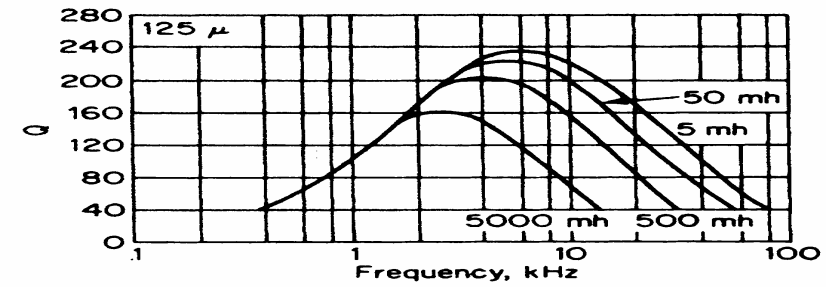
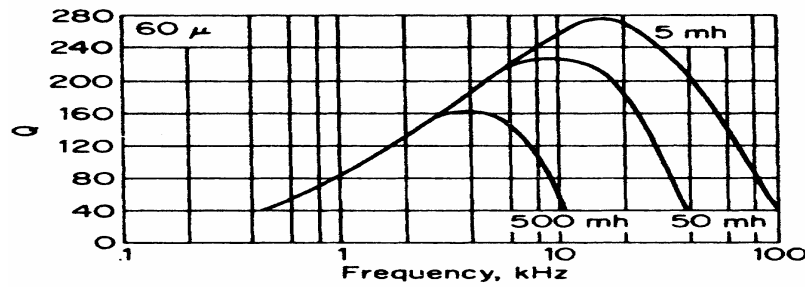

(g) OD = 1.350 in, ID = 0.920 in, HT = 0.350 in

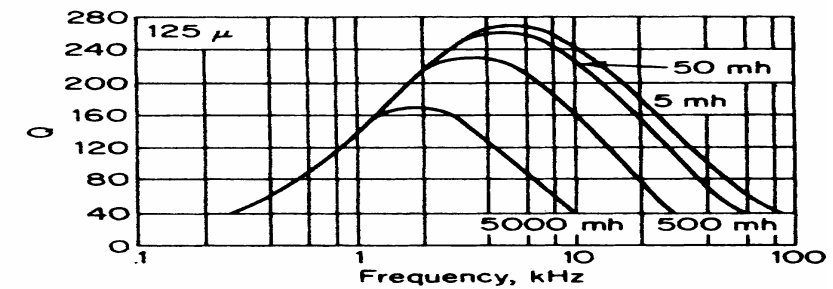
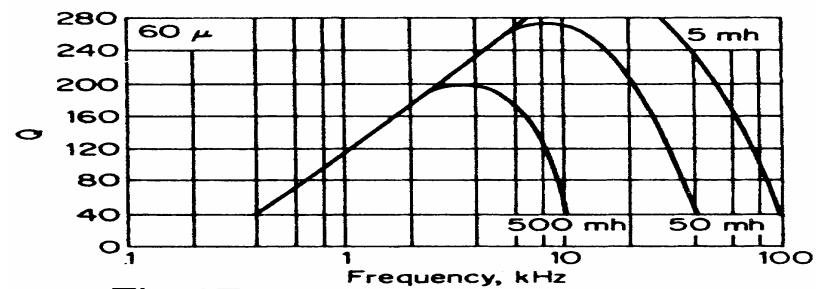

(h) OD = 1.570 in, ID = 0.950 in, HT = 0.570 in

Fig 17
cont'd

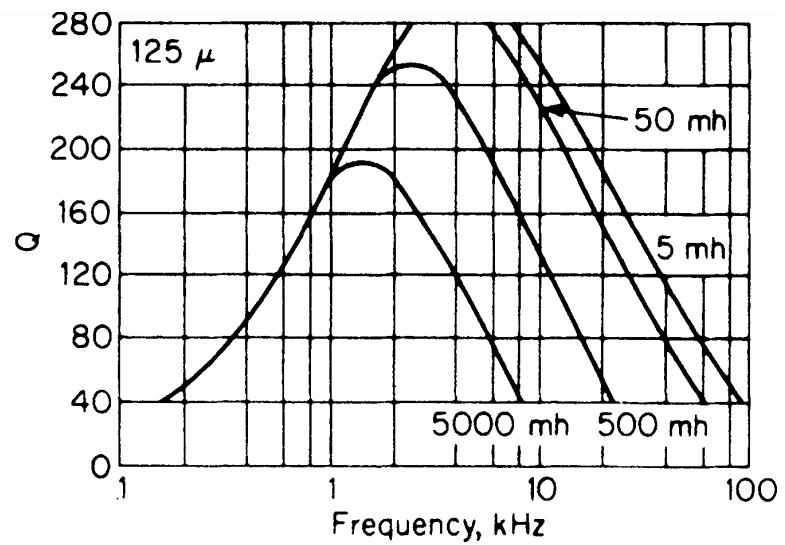
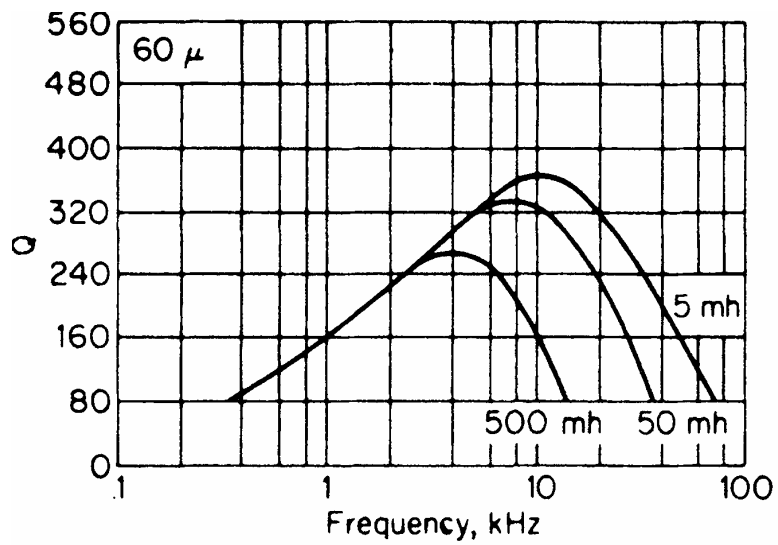

(i) OD = 2.000 in, ID = 1.250 in, HT = 0.530 in

Fig 17
cont'd

POWDERED IRON TOROIDS

- Above 1 or 2 MHz, the core losses of most magnetic materials become prohibitive. Toroidal cores composed of compressed iron powder known as carbonyl iron are then desirable for use up to the VHF range.
- These cores are comprised of finely divided iron particles which are insulated and then compressed at very high pressures into a toroidal shape in a manner similar to MPP cores.
- The high resistance resulting from the insulation in conjunction with the very small particles results in good high frequency performance. In effect air gaps are distributed throughout the structure.
- Permeability can be controlled to tight tolerances and result in low temperature coefficients. Saturation levels of iron are high compared to other magnetic materials.

Material Selection

- Multiple iron powders in the carbonyl iron family are available depending on the frequency band of interest.
- The more popular materials are listed in Table 6 along with their nominal permeability, temperature coefficient, and recommended frequency of operation. Above this range the core losses can become excessive.
- Major suppliers of these cores are Micrometals and Amidon. Their nomenclature for the various materials is used in the tables. As a general rule a material should be selected that has the highest permeability over the frequency range of operation.
- The last item in the table is a Phenolic core which is basically an air core with a μ of 1. Air will never saturate. The temperature coefficient is 0.

Table 6

Iron-Powder Core Materials

Micrometals & Amidon Designation	Type of Iron Powder	Frequency range of Operation	Material Permeability μ	Temperature Stability ppm/ °C
-1	Carbonyl C	150KHz to 3MHz	20	280
-2	Carbonyl E	250KHz to 10MHz	10	95
-3	Carbonyl HP	20KHz to 1MHz	35	370
-4	Carbonyl J	3MHz to 40MHz	9	280
-6	Carbonyl SF	3MHz to 40MHz	8.5	35
-7	Carbonyl TH	1MHz to 25MHz	9	30
-8	Carbonyl GQ4	20KHz to 1MHz	35	255
-10	Carbonyl W	15MHz to 100MHz	6	150
-15	Carbonyl GS6	150KHz to 3MHz	25	190
-17	Carbonyl	20MHz to 200MHz	4	50
-42	Hydrogen Reduced	300KHz to 80MHz	40	550
-0	Phenolic	50MHz to 350MHz	1	0

- The following two figures illustrate the saturation characteristics of various Powered Iron core materials.
- Figure 18 shows the percentage reduction of permeability with a DC bias.
- Figure 19 illustrates an ***Increase in permeability*** with an increase in flux density which eventually reverses. This implies the inductance will initially increase for a flux density of 50 Gauss and more.

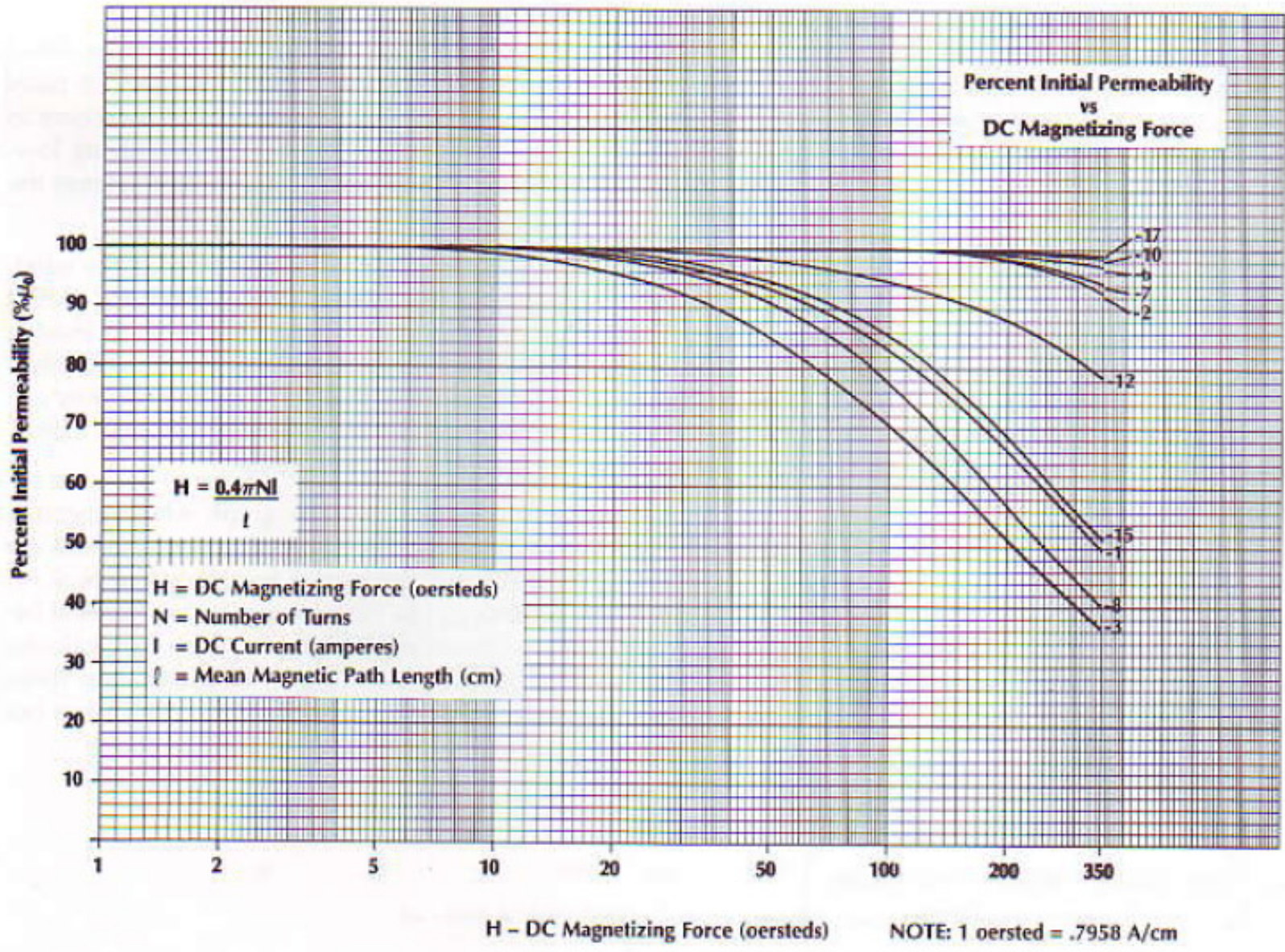

Courtesy Micrometals

Fig 18

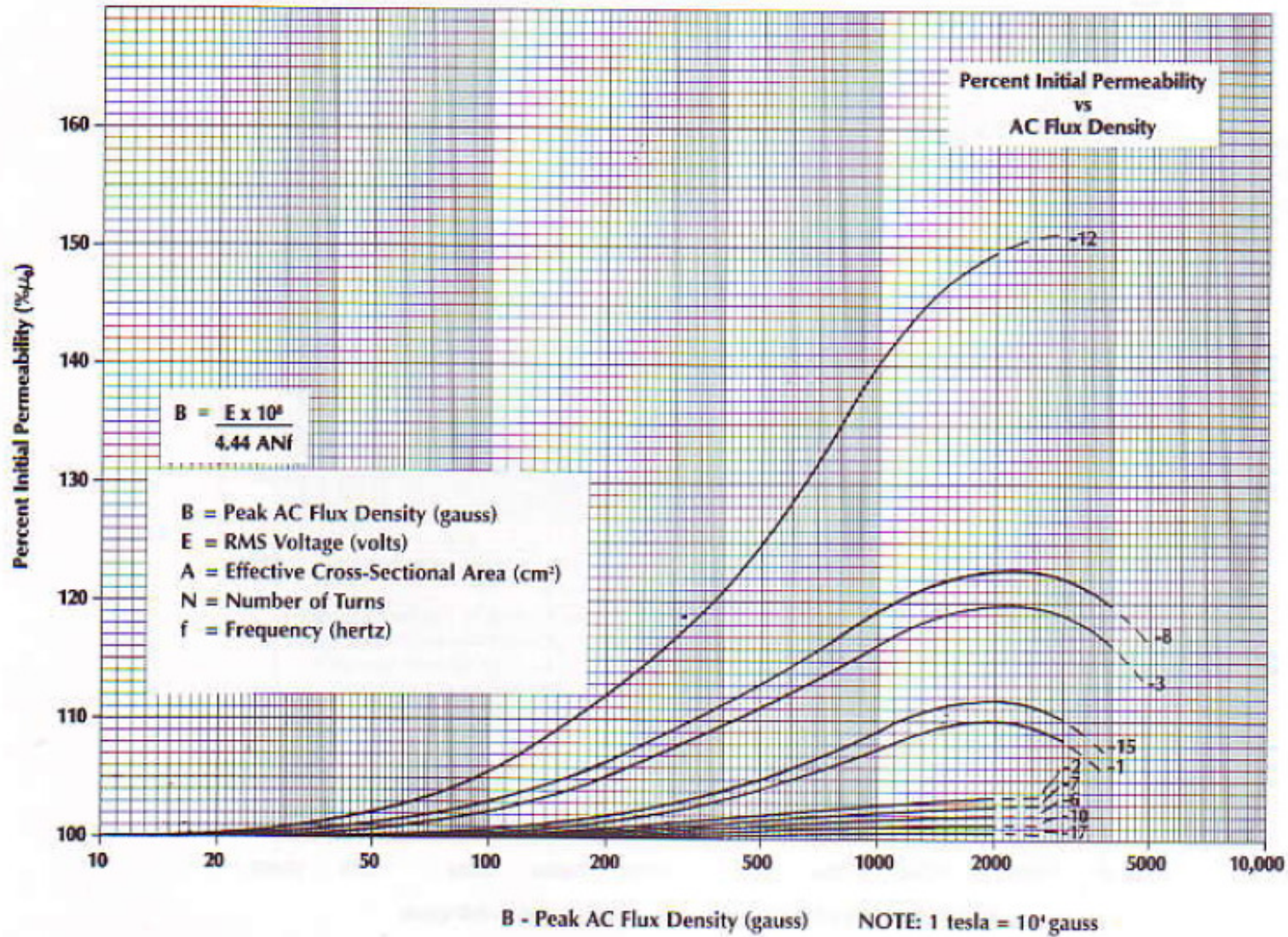

Courtesy Micrometals

Fig 19

Once a core size and material is selected based on the previous table and available Q curves, table 7 provides the A_L per 100 turns.

Table 7

Powdered-Iron Toroidal Core Sizes

Micrometals & Amidon Size Designation	OD, in	ID, in	HT, in	Cross Sect cm ²	Path Length cm	Material	Material #	A_L $\mu\text{H}/100$ T
T12	0.125	0.062	0.05	0.01	0.73	HP	3	60
						C	1	28
						E	2	20
						TH	7	10
						SF	6	9
						W	10	12
T20	0.2	0.088	0.07	0.025	1.15	HP	3	76
						C	1	52
						E	2	25
						TH	7	23
						SF	6	22
						W	10	16
T30	0.309	0.151	0.128	0.065	1.5	HP	3	140
						C	1	85
						E	2	43
						TH	7	37
						SF	6	36
						W	10	25

- To calculate the required number of turns for a given inductance use the following relationship:

$$N=100 \sqrt{\frac{\text{Desired } L \text{ } \mu\text{H}}{A_L \text{ (}\mu\text{H/100 turns)}}$$

Table 7

Continued

Micrometals & Amidon Size Designation	OD, in	ID, in	HT, in	Cross Sect cm ²	Path Length cm	Material	Material #	A _L μH/100 T
T50	0.5	0.3	0.187	0.121	3.03	HP	3	175
						C	1	100
						E	2	49
						TH	7	43
						SF	6	40
						W	10	31
T80	0.8	0.5	0.25	0.242	5.15	HP	3	180
						C	1	115
						E	2	55
						TH	7	50
						SF	6	45
						W	10	32
T106	1.06	0.58	0.44	0.69	6.54	HP	3	450
						C	1	280
						E	2	135
						TH	7	133
						SF	6	116
						W	10	92
T157	1.57	0.965	0.57	1.14	11.46	HP	3	420
						C	1	320
						E	2	140
						TH	7	117
						SF	6	115
						W	10	98

MAXIMIZING COIL Q

- Although we covered various toroidal coil winding methods in the MPP core section Powdered Iron coils are approached differently. Since copper losses are not dominant from 1MHz or so up the objective is to minimize core losses and C_d and not try to fill the core window up with the heaviest wire possible.
- Maximum Q occurs at the frequency where the core losses are equal to the winding loss. For a given core material the frequency at which this peak occurs is inversely proportional to core size. Larger cores peak at lower frequencies. Also larger cores tend to have higher peak Qs' than smaller cores.
- Core losses are minimized by selecting the most suitable core material. Distributed capacitance is minimized by using the best winding method.
- Litz wire may help reduce skin effect for up to 1MHz but for higher frequencies its use is become uncommon. It also adds distributed capacitance due to its larger surface area.
- Generally speaking distributed capacitive effects become more important with F^2 . The most effective way to control distributed capacitance is by limiting the winding to a single layer.

The following figure illustrates a few examples of single-layer toroidal coils.



Fig 20



- To determine the wire size for a given number of turns, assuming a single layer winding, use Table 8.
- The resulting inductance of a single layer powdered iron toroid can not be precisely predicted due to the effect of leakage inductance, (uncoupled flux). The further apart the turns are, the lower the resulting inductance will be due to reduced flux linkage between turns.
- For best results the turns should be evenly spread around the core. In practice toroidal coils are sometimes tuned by adjusting the separation between turns. The following figure illustrates the variation of inductance for a 0.5" OD toroid of carbonyl material having 10 turns of 20AWG wire as the turns are compressed, while maintaining a single layer. It is not uncommon to adjust or tune the inductor by squeezing turns.

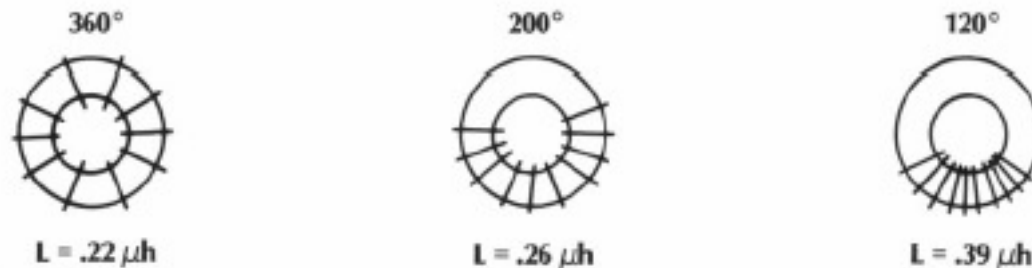

Fig 21

Table 8

SINGLE LAYER TURNS TABLE

WIRE SIZE(AWG)	40	38	36	34	32	30	28	26	24	22	20
<u>PART NO</u>	NUMBER OF TURNS										
T12	43	33	26	20	15	11	8	5	3	1	
T20	57	44	34	27	20	15	11	8	5	3	2
T30	110	86	69	54	42	33	25	20	15	11	7
T50	239	187	151	121	94	76	59	47	37	28	22
T80	402	316	255	204	161	129	103	82	64	51	39
T106	462	362	293	235	185	149	118	95	74	59	46
T157	784	616	499	401	316	256	204	164	129	103	81

- To minimize dielectric losses, Teflon-coated wire is occasionally used since this material has an extremely small power factor (low loss) compared to the more commonly used polyurethane insulation. However Teflon insulation is not easily stripped.
- Also, wrapping the core itself with Teflon or Mylar tape prior to applying the winding helps to keep stray capacity low.
- If potting compounds are used, they should be very carefully chosen, since inductor Q s can be easily degraded when impregnated by lossy materials.

Q CURVES

Figure 22 contains representative Q curves that can be obtained for various core sizes, inductances and materials. All coils are wound single-layer.

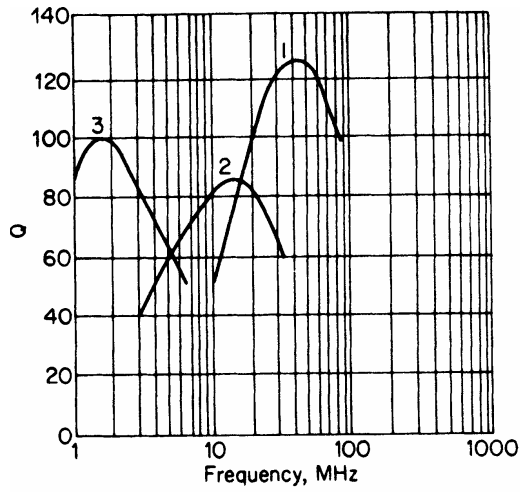

Curve	Material	Winding	L
1	W	11T#30	0.1 μ H
2	TH	25T#36	0.6 μ H
3	C	50T#40	7 μ H

OD=0.120 in, ID=0.062 in, HT=0.035 in

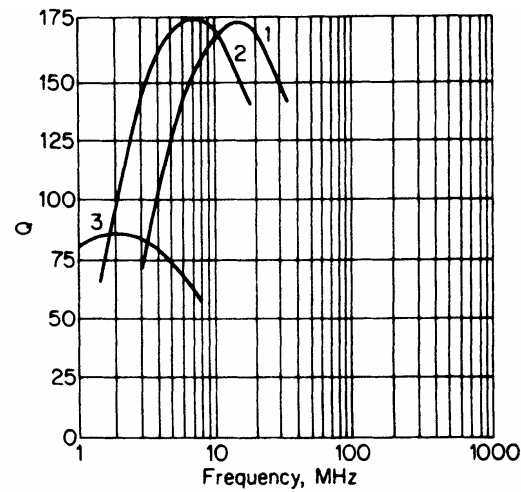

Curve	Material	Winding	L
1	SF	17T#26	1 μ H
2	E	29T#28	5 μ H
3	C	50T#32	2.6 μ H

OD=0.309 in, ID=0.156 in, HT=0.125 in

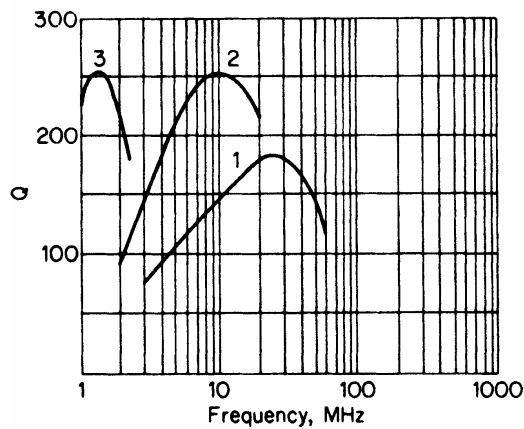

Curve	Material	Winding	L
1	W	10T#20	0.35 μ H
2	SF	19T#20	1.4 μ H
3	E	125T#15/44	73 μ H

OD=0.500 in, ID=0.300 in, HT=0.187 in

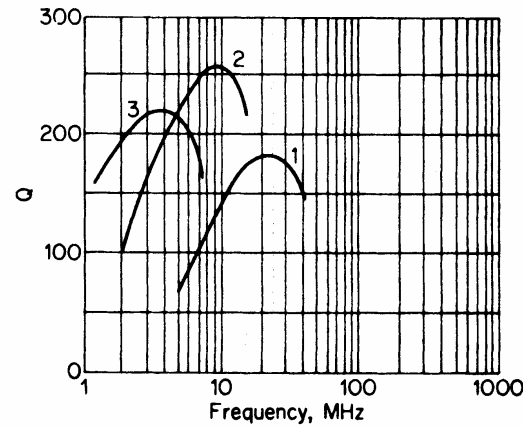

Curve	Material	Winding	L
1	W	10T#20	0.4 μ H
2	SF	25T#22	3 μ H
3	E	45T#26	12 μ H

OD=0.800 in, ID=0.500 in, HT=0.250 in

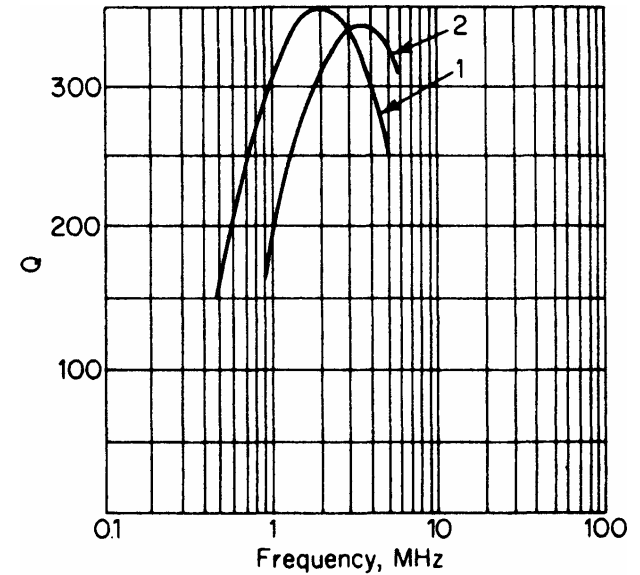

Curve	Material	Winding	L
1	E	40T#20	21 μ H
2	E	20T#16	5 μ H

OD=1.06 in, ID=0.58 in, HT=0.44 in

Fig 22

FERRITE INDUCTORS

- Ferrites are ceramic structures created by combining iron oxide with oxides or carbonates of other metals such as manganese, nickel, or magnesium. The mixtures are pressed, fired in a kiln at very high temperatures, and machined into the required shapes. The major difference between ferrites and most other magnetic materials is that ferrites are non-metallic since they are comprised of oxide materials.
- They are well suited for low power applications such as high Q inductors. Use of ferrite for high power inductors is achieved by increasing cross-sectional area to prevent saturation. The operating frequency range falls somewhere between MPP cores and Powdered Iron typically 10KHz to 1 or 2 MHz.
- The major advantage of ferrites over MPP cores is their high resistivity so that core losses are kept low even at higher frequencies, where eddy-current losses become significant.

- Additional properties such as high permeability and good stability with time and temperature often make ferrites the best core-material choice for the intermediate frequency range.
- The Curie temperature is the temperature where a magnetic material becomes non-magnetic. Ferrite and Powdered iron typically has a much higher Curie temperature than MPP ($\cong 700^{\circ}\text{C}$). However wire insulation and other associated materials will melt much before that temperature is reached so Ferrite offers no practical advantage in this area.
- There are a number of major manufacturers of ferrite cores; Magnetics Inc., Ferroxcube, TDK and EPCOS. They have different numbering systems for their cores and materials but appear to have somewhat parallel product lines.

- This figure illustrates a Pot Core assembly. A winding supported on a bobbin is mounted within a set of symmetrical ferrite pot core halves. The assembly is rigidly held together by a metal clamp.
- An air gap is introduced in the center post of each half, and only the outside surfaces of the pot core halves mate with each other.
- By introducing an adjustment slug containing a ferrite sleeve, the effect of the gap can be partially neutralized as the slug is inserted into the gap region and bypasses the gap to an extent. Typically the inductance can be increased by 12% providing a +/-6% adjustment range.

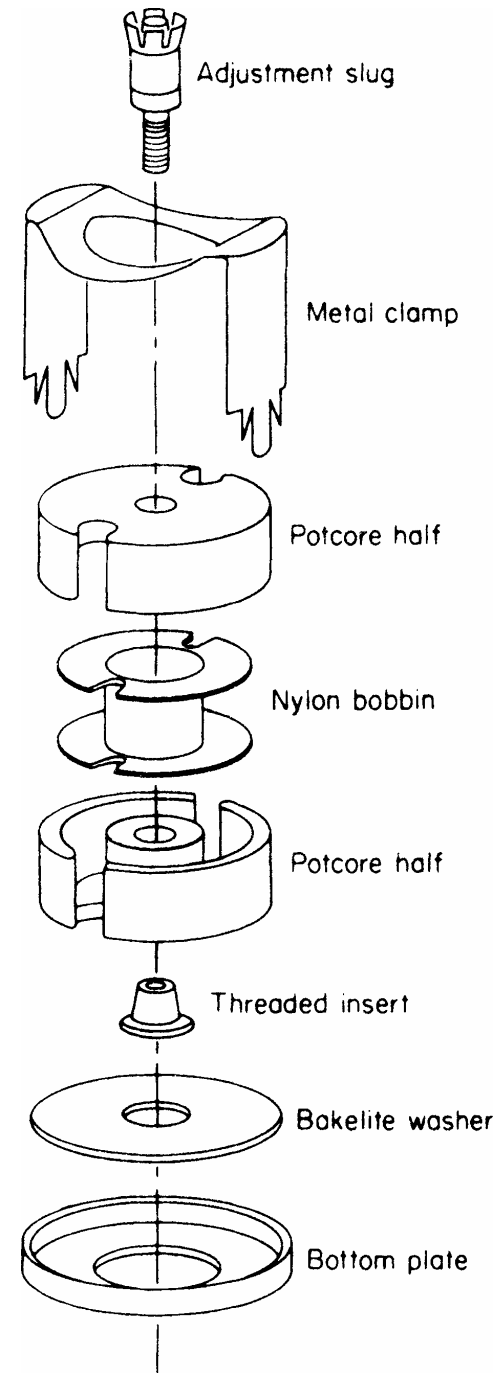

Fig 23

- Pot cores have been standardized into nine international sizes ranging from 9 x 5 to 42 x 29 mm, where these dimensions represent the approximate diameter and height, respectively, of a pot core pair. These sizes are summarized in Table 9.

Table 9
Standard Pot core Sizes

Core Size Designation	Diameter (max)		Height (max)		Cross Section, cm ²	Path Length, cm
	in	mm	in	mm		
905	0.366	9.3	0.212	5.4	0.101	1.25
1107	0.445	11.3	0.264	6.7	0.167	1.55
1408	0.559	14.2	0.334	8.5	0.251	1.98
1811	0.727	18.5	0.426	10.8	0.433	2.58
2213	0.858	21.8	0.536	13.6	0.635	3.15
2616	1.024	26.0	0.638	16.2	0.948	3.76
3019	1.201	30.5	0.748	19.0	1.38	4.52
3622	1.418	36.0	0.864	22.0	2.02	5.32
4229	1.697	43.1	1.162	29.5	2.66	6.81

- Ferrite pot cores have a number of distinct advantages over other shapes. Since the wound coil is contained within the ferrite core, the structure becomes *self-shielding*, since stray magnetic fields are prevented from entering or leaving the structure.
- High Q s and good temperature stability can be achieved by appropriate selection of materials and by controlling the effective permeability μ_e through the air gap.
- A high resolution continuous adjustment of the effective permeability is accomplished using the adjustment slug. In contrast toroids have to be adjusted by adding or removing turns.

- Multi-section bobbins can be used to reduce distributed capacitance by creating partitions between sections of the winding. The following shows a 3-section bobbin where 1/3 of the required number of turns is placed in each section. The wire size would need to be reduced one or two gauges.

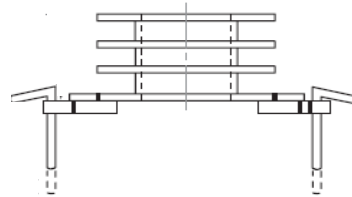

- Multiple bobbins can be wound at the same time by placing them all on a shaft and feeding each one from an individual spool of wire whereas toroids can only be wound individually. This reduces cost.



Fig 24

- Table 10 lists the initial permeabilities, maximum frequency and saturation flux density for the more popular Magnetics Inc. Ferrite materials.
- Once a gap is introduced the permeability will decrease and the curves versus temperature, frequency and flux density will significantly flatten.

Table 10

**FERRITE MATERIAL PROPERTIES
MAGNETICS INC.**

Material	R	P	F
Initial Permeability μ_i	2300 \pm 25%	2500 \pm 25%	3000 \pm 20%
Maximum usable frequency (50% roll-off in μ_i)	<1.5MHz	<1.2MHz	<1.3MHz
Saturation Flux Density at 15 Oe in Gauss (B_m)	5000	5000	4900

- Let us first consider initial permeability as a function of frequency. A material should be chosen that provide uniform (flat) permeability over the frequency range of interest.
- Figure 25 indicates that for the two particular Magnetics Inc. materials shown, operation should be restricted to below 1MHz.
- Even if a relatively large variation may occur in the initial permeability, a gapped core will show much less variation.
- As a rule of thumb lower initial permeability materials have wider frequency ranges of operation.

Fig 25

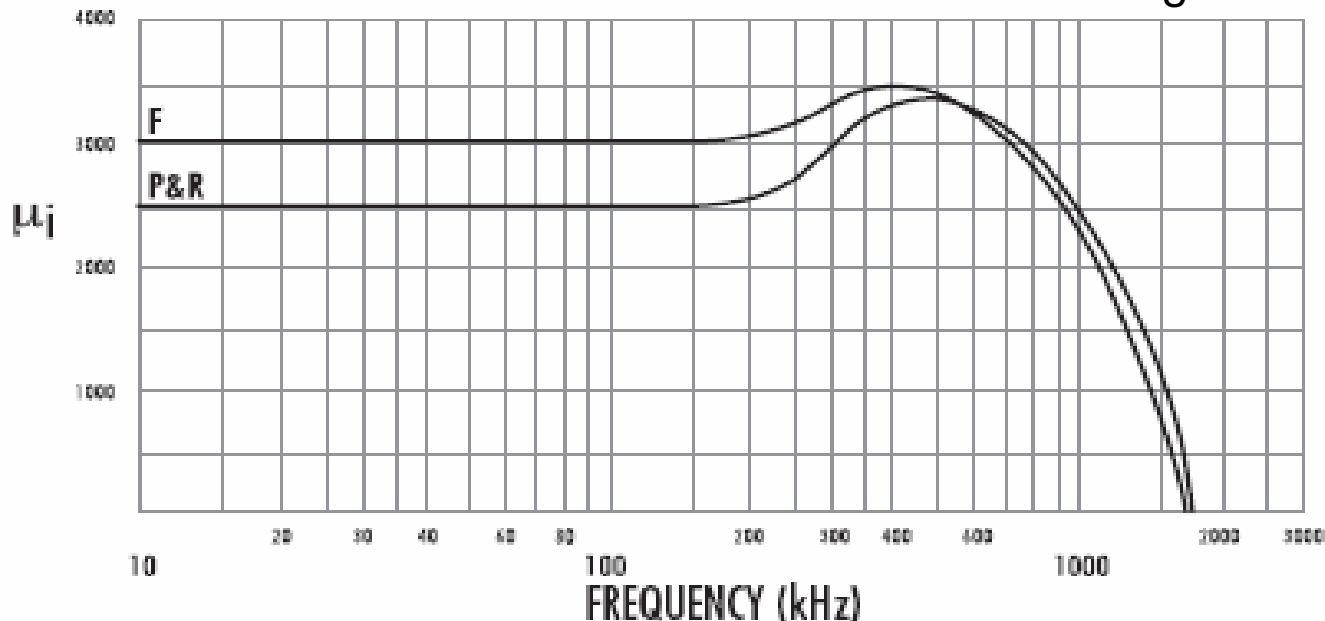

- The following graphs illustrate the effects of temperature on the initial permeability of these materials. A gapped core significantly reduces these effects.

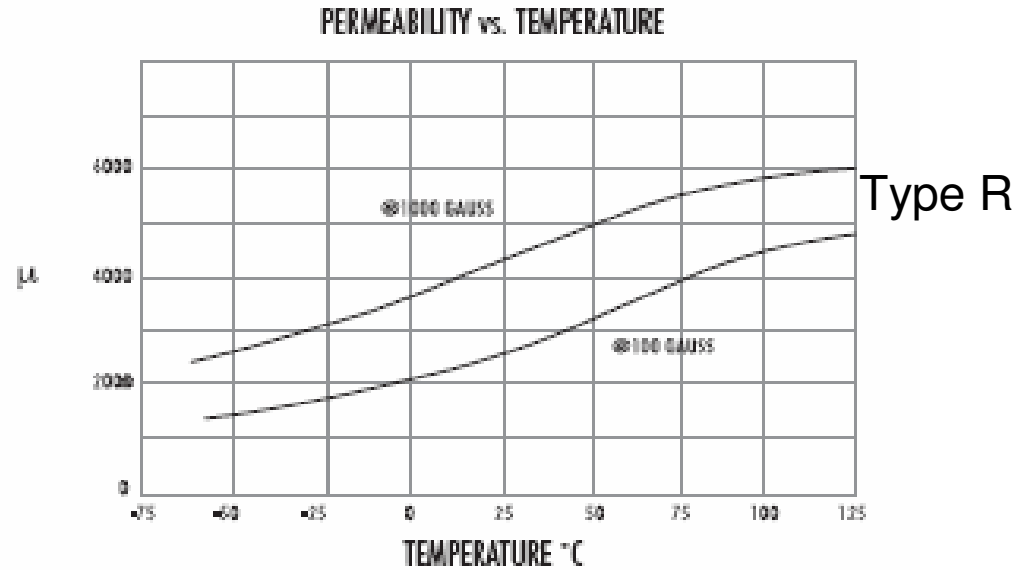

Type P

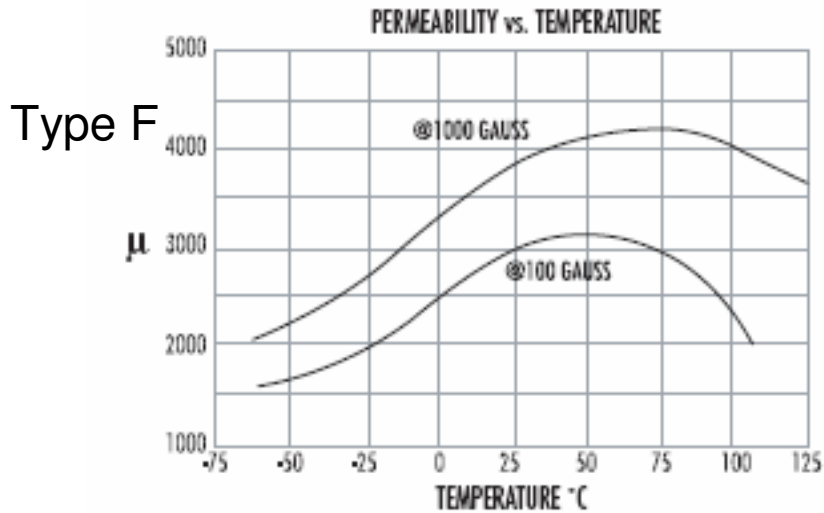
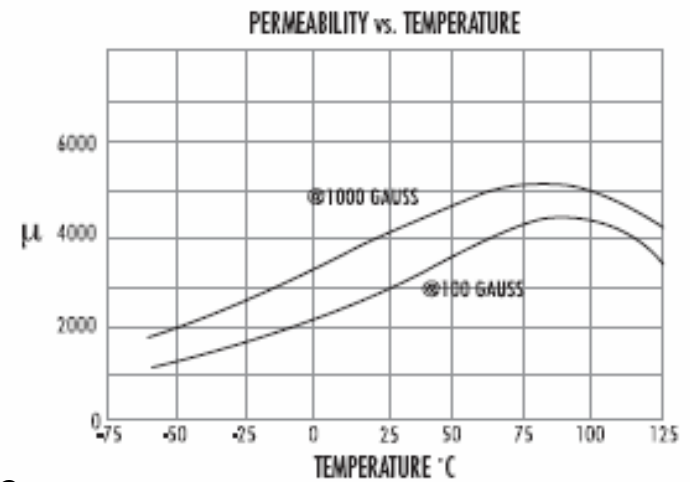

Fig 26



- For a given core, a wide range of A_L factors are available. This parameter is determined by the effective permeability of the core, which in turn is controlled by the initial permeability of the ferrite material, the core dimensions, and the size of the air gap introduced in the center post.
- Table 11 lists the effective permeability and the ohms per henry rating for all the standard core sizes where the A_L is maintained constant at 250 mH. For other values, the effective permeability is proportional to the rated A_L and the ohms per henry is inversely proportional to this same factor.

Table 11

Electrical Properties of Standard Core Sizes for $A_L = 250$ mH

Size Designation	μ_e	Ω/H
905	230	700
1107	184	570
1408	156	380
1811	119	260
2213	98	190
2616	78	170
3019	64	140
3622	52	130
4229	51	80

- Although ferrite pot cores are available in a variety of A_L values depending on the gap, the more popular values of A_L are:
24,40,63,100,160,250,315,400,630,1000 and 1600 (all in mH/1,000 turns)
- Pot cores are also available having no gap. (That is how they are initially manufactured.) However, since the resulting electrical characteristics are essentially equivalent to the initial properties of the ferrite material, these cores should be restricted to applications where high permeability is the dominant requirement, such as wideband transformers.
- Bobbins are normally wound by guiding the wire feed back and forth as the bobbin is rotated. In the event that the inductor's self-resonant frequency is an issue, a multi-section bobbin can be used to reduce distributed capacitance. One section at a time is filled to capacity. Most bobbin sizes are available with up to four sections.
- A wire capacity chart for standard single-section bobbins is shown in Table 12. Multi-section bobbins have slightly less winding area than single-section bobbins, so the wire gauge may require reduction by one or 2 sizes. For maximum Q over the frequency range of 50 kHz to 1 or 2 MHz, litz wire should be used. This may even require a further reduction in wire size.

Wire Capacities of Standard Bobbins

Table 12

Wire Size	905	1107	1408	1811	2213	2616	3019	3622	4229
20							63	100	160
21						50	79	125	200
22						63	100	160	250
23					50	79	125	200	315
24					63	100	160	250	400
25				50	79	125	200	315	500
26		17		63	100	160	250	400	630
27		21	50	79	125	200	315	500	794
28		27	63	100	160	250	400	630	1,000
29		34	79	125	200	315	500	794	1,260
30		43	100	160	250	400	630	1,000	1,588
31	50	54	125	200	315	500	794	1,260	2,000
32	63	68	160	250	400	630	1,000	1,588	2,520
33	79	86	200	315	500	794	1,260	2,000	3,176
34	100	108	250	400	630	1,000	1,588	2,520	4,000
35	125	136	315	500	794	1,260	2,000	3,176	5,042
36	160	171	400	630	1,000	1,588	2,520	4,000	6,353
37	200	216	500	794	1,260	2,000	3,176	5,042	8,000
38	250	272	630	1,000	1,588	2,520	4,000	6,353	10,086
39	315	343	794	1,260	2,000	3,176	5,042	8,000	
40	400	432	1,000	1,588	2,520	4,000	6,353	10,086	
41	500	544	1,260	2,000	3,176	5,042	8,000		
42	630	686	1,588	2,520	4,000	6,353	10,086		
43	794	864	2,000	3,176	5,042	8,000			
44	1,000	1089	2,520	4,000	6,353	10,086			
45	1,260	1372	3,176	5,042	8,000				

- As a result of the air gap, the permeability is not uniform throughout the interior of the pot core. If the bobbin is only partially filled because the wire size is too small, the A_L will be reduced as a function of the relative winding height. The decrease in A_L for a 2616 size core can be approximated from the following graph. This effect becomes more pronounced as the gap is made larger.
- For maximum Q it is best to use the largest wire size that will fill up the bobbin.

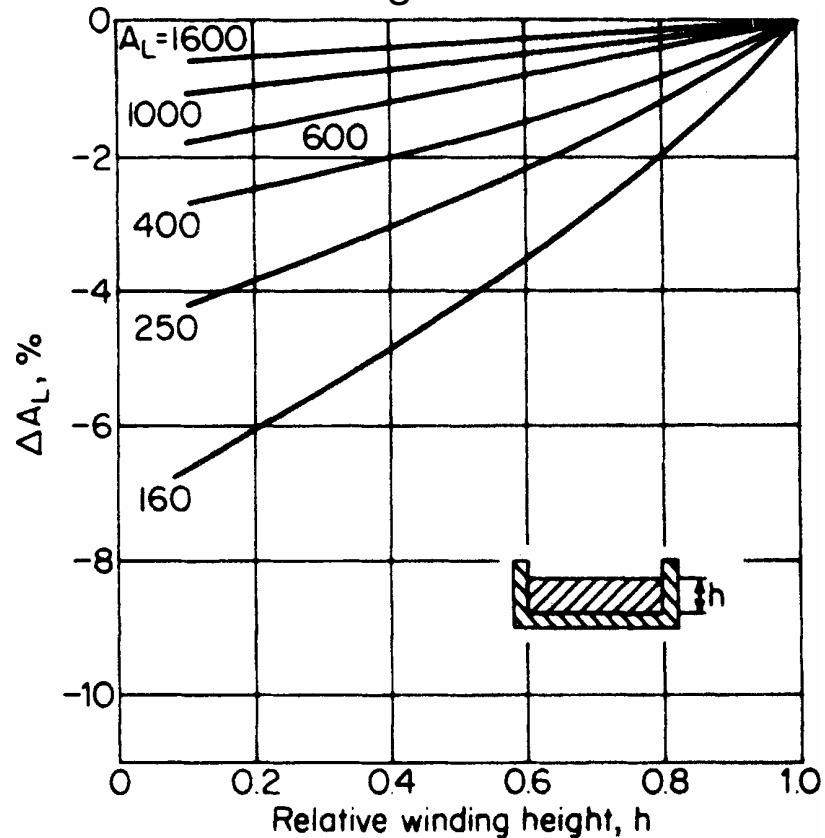

Fig 27

- Various methods are used by designers to estimate the optimum core size, material, and gap for a particular application. Depending upon the requirements, some parameters are more significant than others. *To some extent a bit of trial and error may be necessary.*
- Generally, Q and temperature coefficient are the most important. For a given core size, the *lowest* A_L (largest gap) which provides acceptable Q should be chosen to minimize temperature coefficient and saturation effects. Operation should be restricted to the rising portion of the Q curves to avoid the effects of core and dielectric losses as well as those of self-resonance.
- In general, larger cores provide higher Q , lower temperature coefficient, and better immunity from saturation.
- The following Q curves from Magnetics Inc. are for their G material which is no longer available. However the material is similar to their currently available R material so they can represent a good starting point.

Core Size 7mm x 4mm Material G

BOBBIN WINDING AREA (Per Section)	BOBBIN INFORMATION		
	Number	Turns	Wire
Single Sect. <u>.025</u> cm ²	1	14	30/44
	2	20	20/44
	3	32	12/44
Double Sect. <u>*</u>	4	54	5/44
	5	78	#35
	6	112	#37
Triple Sect. <u>*</u>	7	190	#40
*Not available			

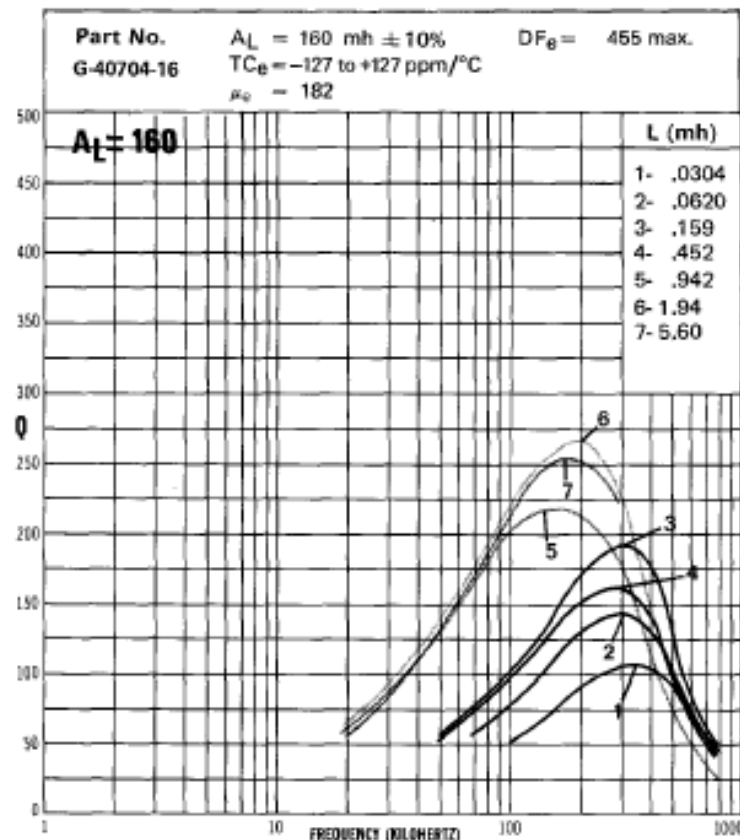
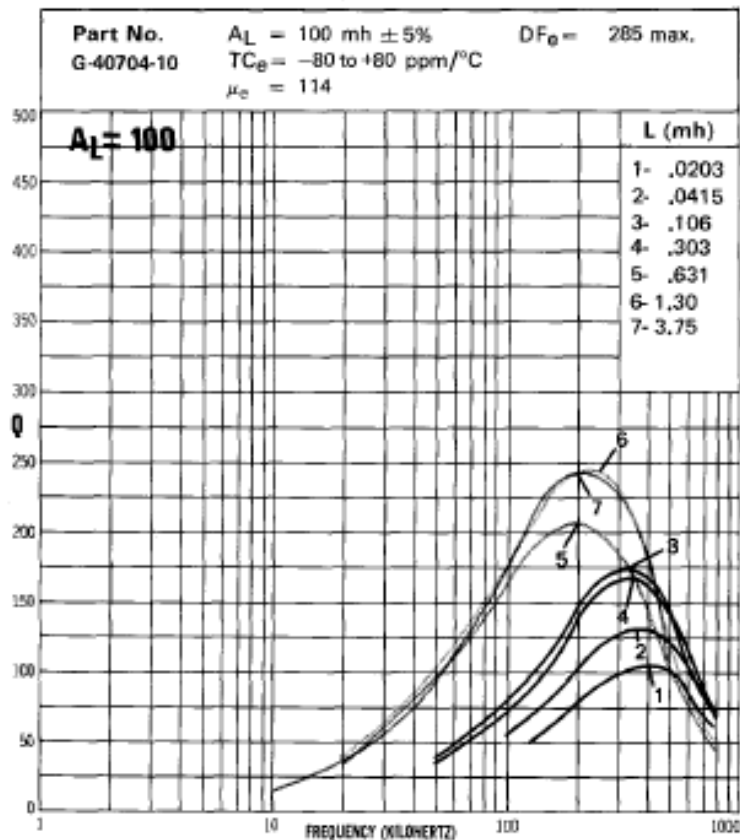

Fig 28

Core Size 9mm x 5mm Material G

BOBBIN WINDING AREA (Per Section)	BOBBIN INFORMATION		
	Number	Turns	Wire
Single Sect. <u>.03</u> c m ²	1	18	30/44
	2	24	20/44
	3	45	12/44
Double Sect. <u>*</u>	4	65	5/44
	5	96	#35
	6	156	#37
Triple Sect. <u>*</u>	7	250	#40
*Not available			

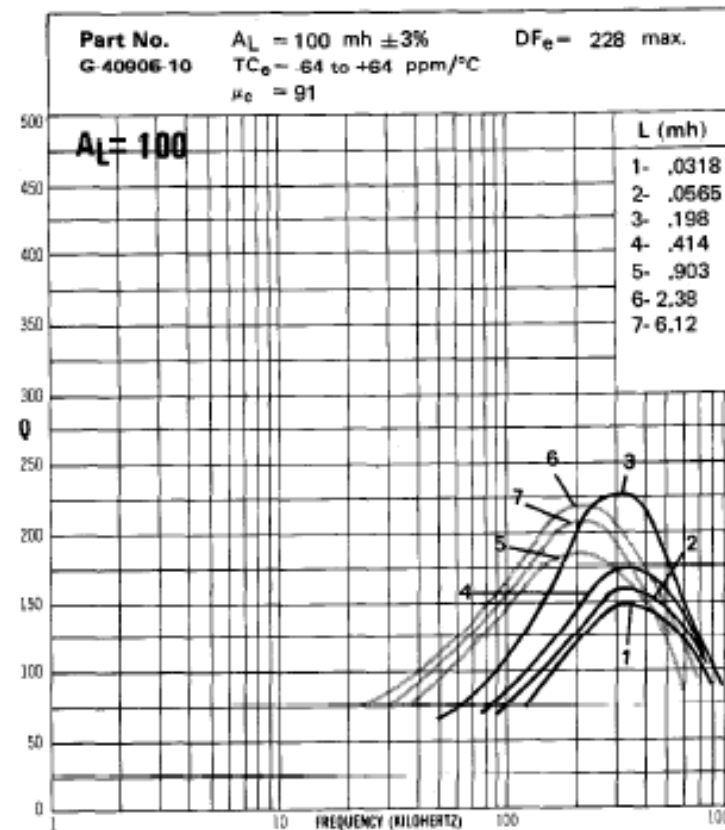
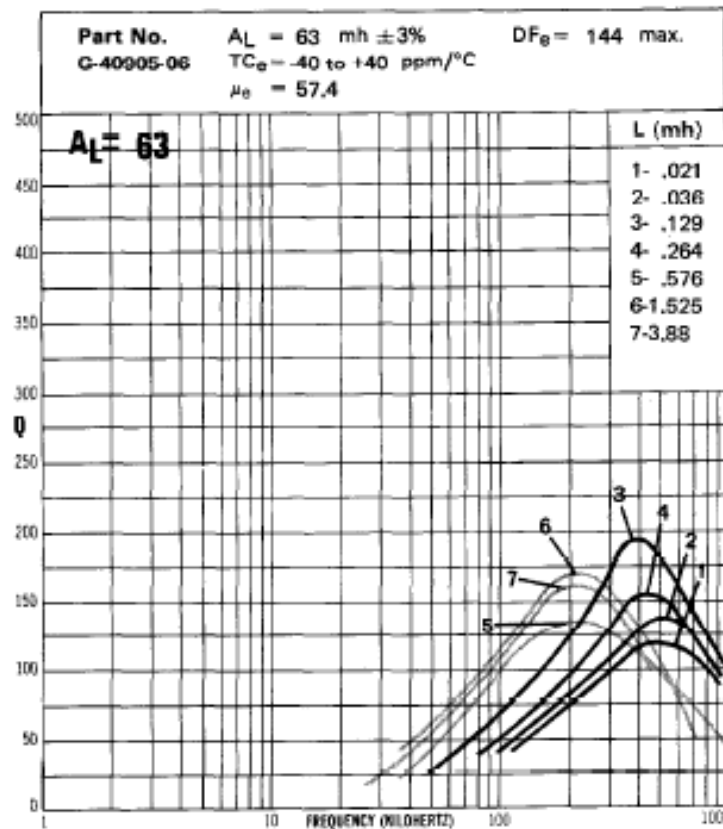

Fig 29

Core Size 11mm x 7mm Material G

All measurements made on single section bobbins

BOBBIN WINDING AREA (Per Section)	BOBBIN INFORMATION		
	Number	Turns	Wire
Single Sect. <u>.05</u> cm ²	1	32	30/44
	2	43	20/44
	3	90	12/44
Double Sect. <u>.022</u> cm ²	4	140	5/44
	5	200	#35
	6	245	#37
Triple Sect. <u>*</u>	7	470	#40
	*Not available		

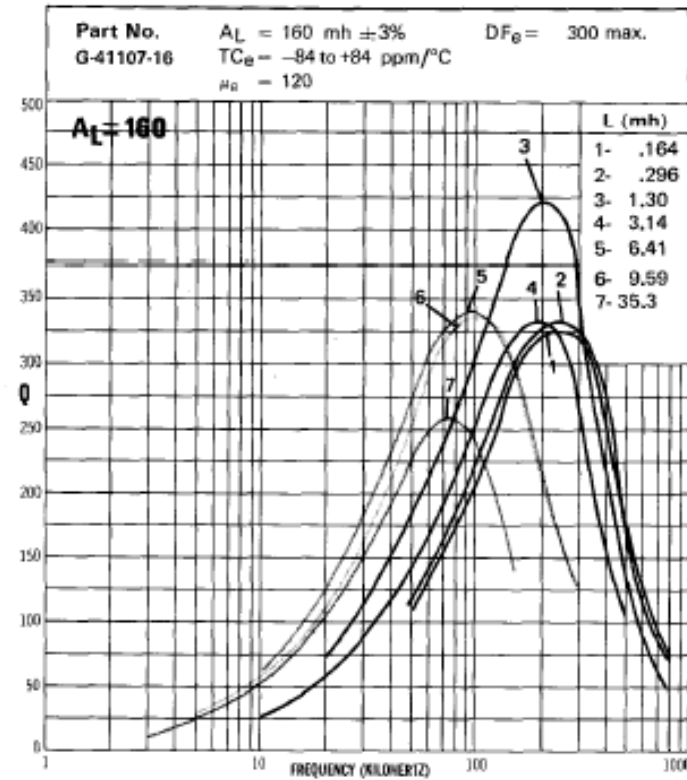
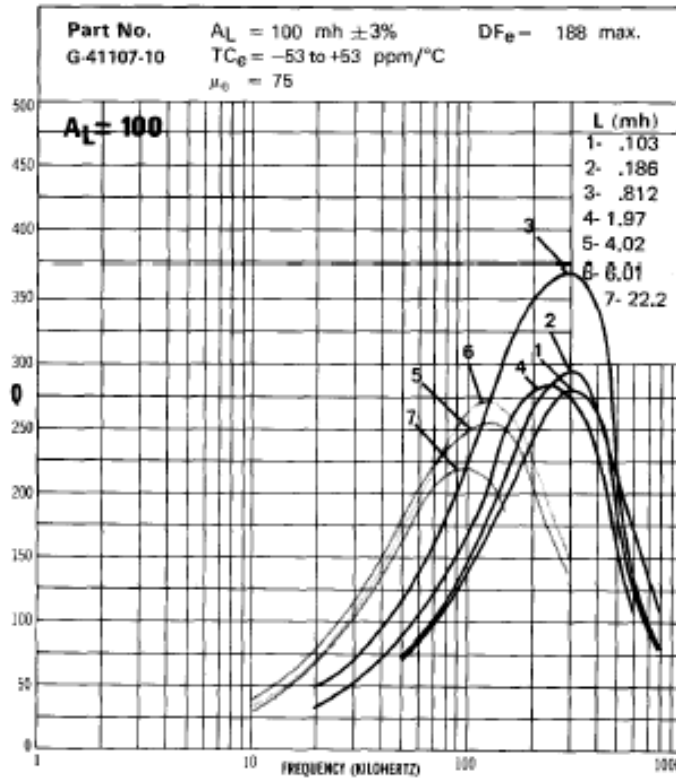

Fig 30

Core Size 14mm x 8mm Material G

All measurements made on single section bobbins except where noted.

BOBBIN WINDING AREA (Per Section)	BOBBIN INFORMATION		
	Number	Turns	Wire
Single Sect. <u>.098</u> cm ²	1	24	80/44
	2	33	40/44
	3	66	20/44
Double Sect. <u>.044</u> cm ²	4	132	12/44
	5	154	#32
	6	360	#36
Triple Sect. <u>*</u>	7	760	#40
*Not available (D) Double Section	8	58	20/44(D)

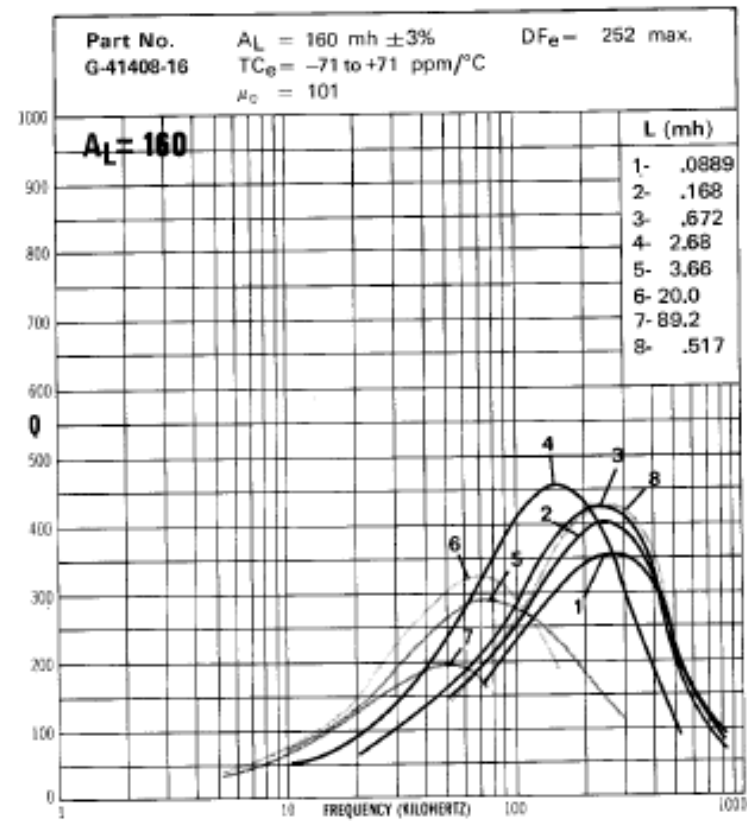
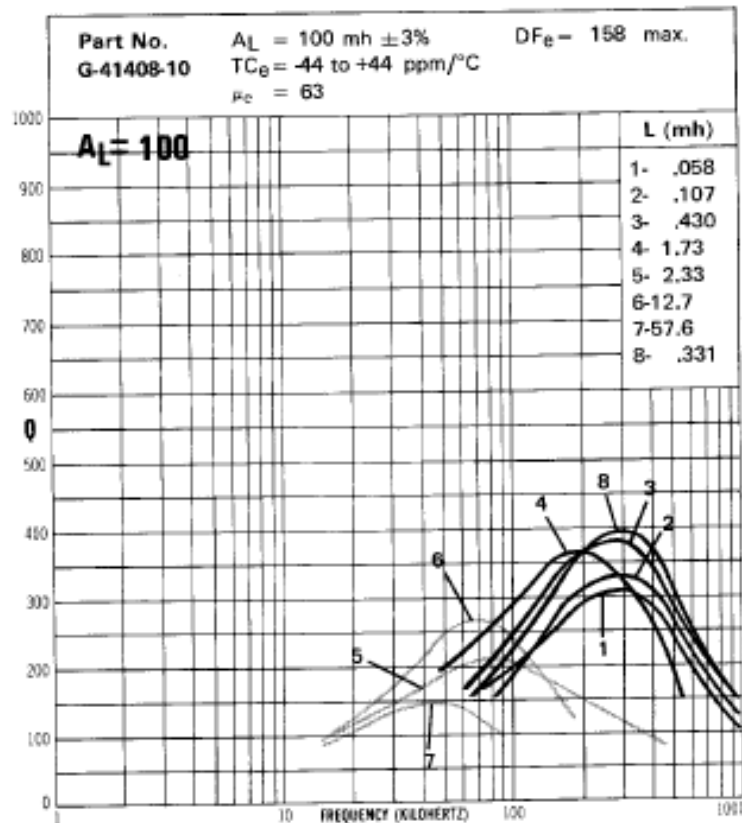

Fig 31

Core Size 18mm x 11mm Material G

BOBBIN WINDING AREA (Per Section)	BOBBIN INFORMATION		
	Number	Turns	Wire
Single Sect. <u>1.7</u> cm ²	1	42	80/44
	2	70	40/44
	3	138	20/44
Double Sect. <u>0.84</u> cm ²	4	288	12/44
	5	300	#32
	6	700	#36
Triple Sect. <u>.049</u> cm ²	7	950	#38
(D) Double Section	8	60	40/44(D)

All measurements made on single section bobbins except where noted.

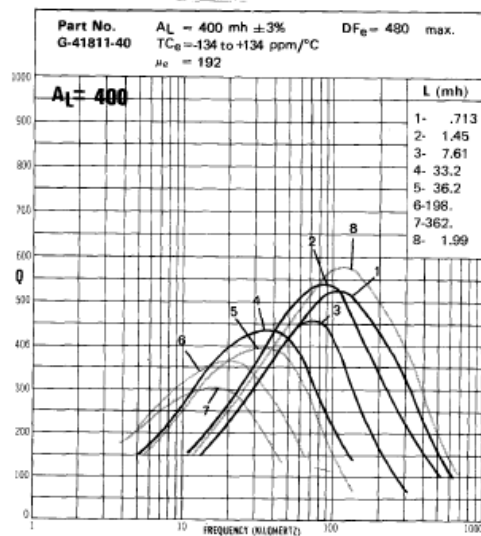
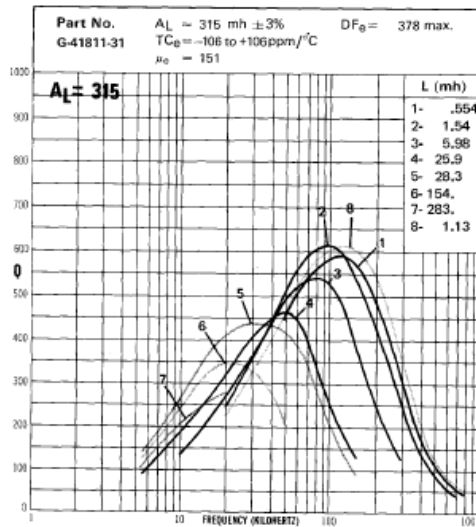
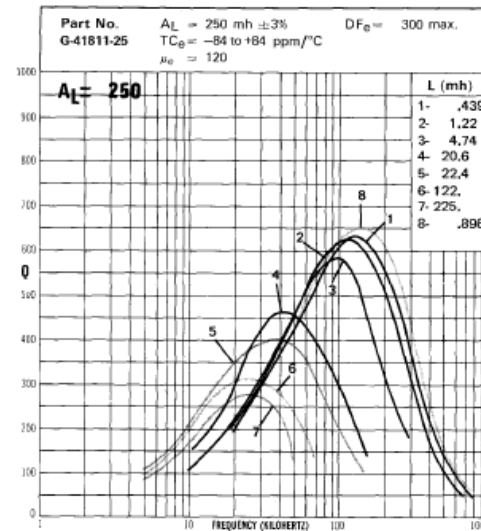
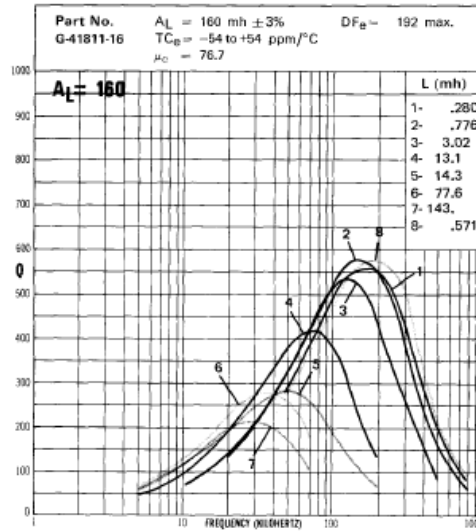

Fig 32

Core Size 22mm x 13mm Material G

All measurements made on single section bobbins except where noted.

BOBBIN WINDING AREA (Per Section)	BOBBIN INFORMATION		
	Number	Turns	Wire
Single Sect <u>.292</u> cm ²	1	50	100/44
	2	66	80/44
	3	95	60/44
	4	105	40/44
Double Sect <u>.138</u> cm ²	5	226	20/44
	6	450	#32
	7	735	#34
Triple Sect <u>.087</u> cm ²	8	1100	#36
(D) Double Section	9	58	80/44(D)

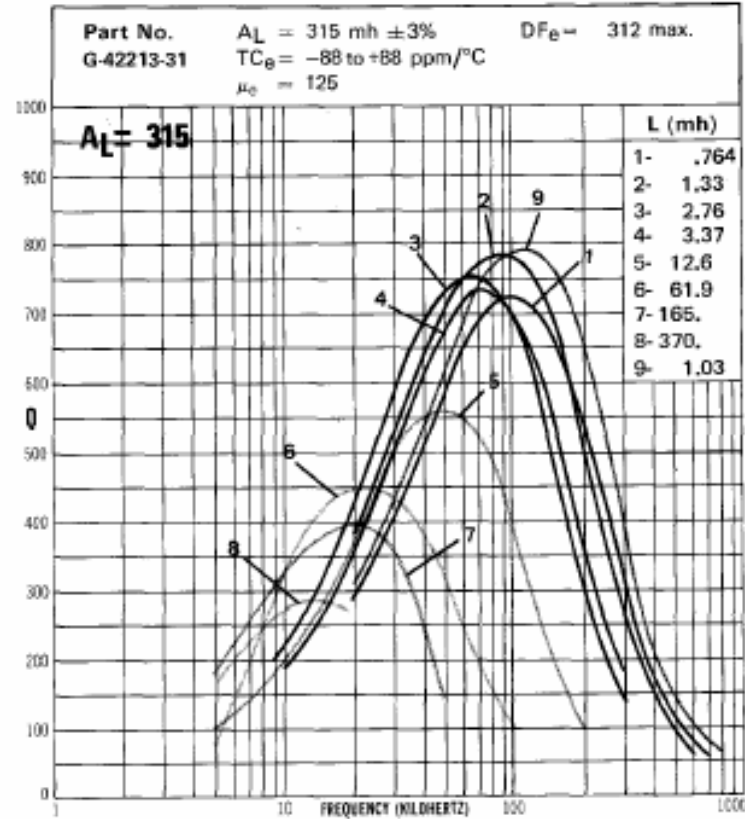
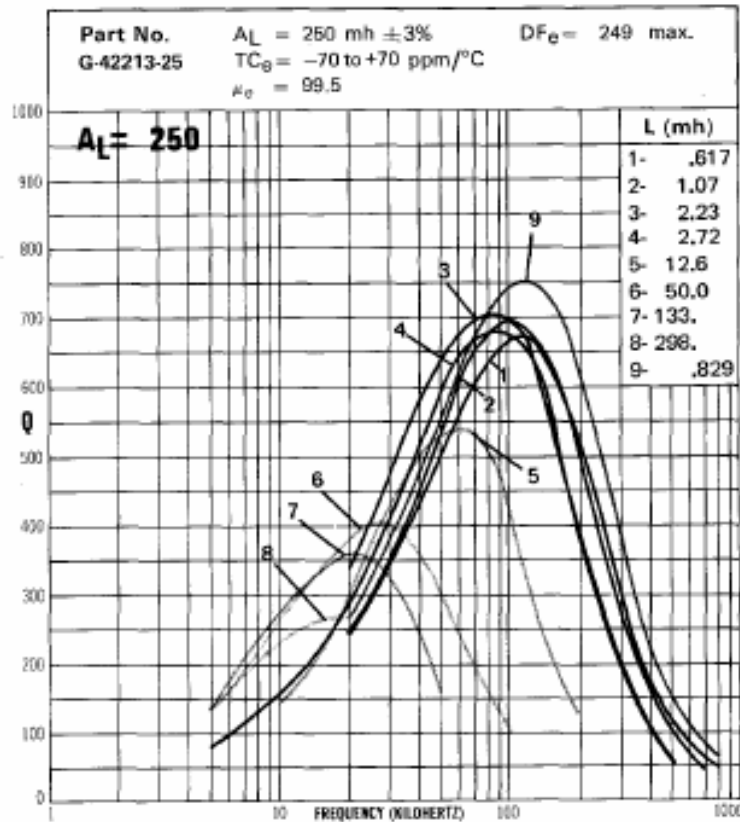

Fig 33

Core Size 26mm x 16mm Material G

All measurements made on single section bobbins except where noted.

BOBBIN WINDING AREA (Per Section)	BOBBIN INFORMATION		
	Number	Turns	Wire
Single Sect. <u>.421</u> cm ²	1	72	100/44
	2	95	80/44
	3	153	60/44
	4	166	40/44
Double Sect. <u>.202</u> cm ²	5	332	#28
	6	640	#32
Triple Sect. <u>.128</u> cm ²	7	1500	#36
(D) Double Section	8	90	80/44(D)

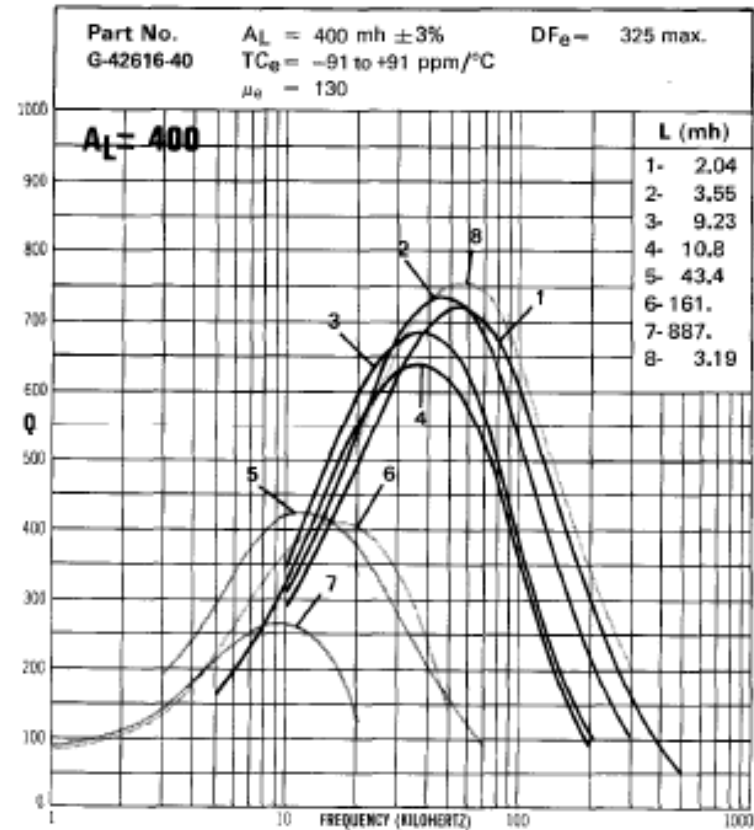
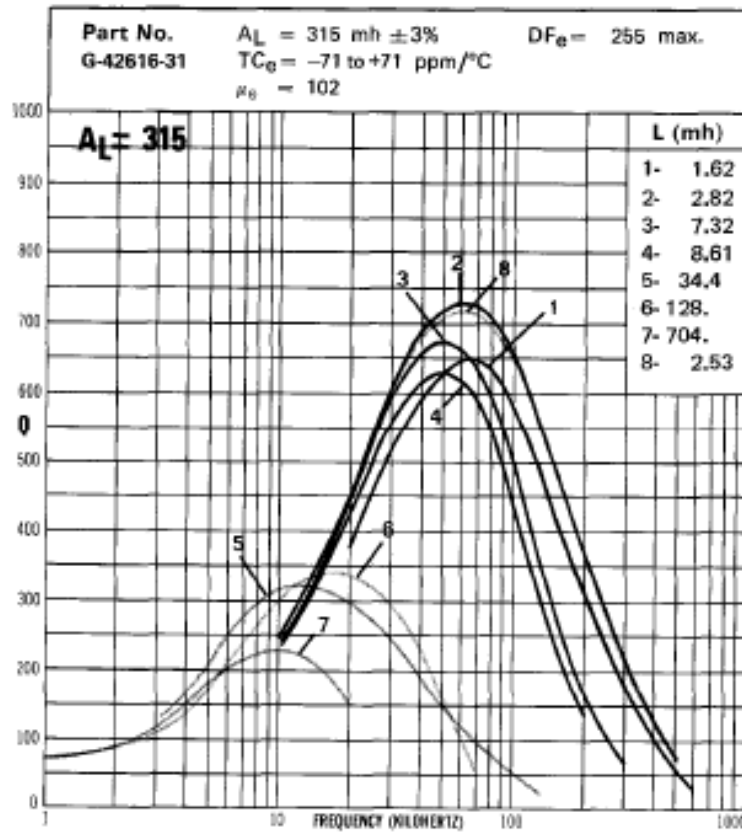

Fig 34

Core Size 30mm x 19mm Material G

All measurements made on single section bobbins except where noted.

BOBBIN WINDING AREA (Per Section)	BOBBIN INFORMATION		
	Number	Turns	Wire
Single Sect. <u>.542</u> cm ²	1	53	180/44
	2	102	100/44
	3	149	80/44
Double Sect. <u>.254</u> cm ²	4	205	60/44
	5	400	#28
Triple Sect. <u>.159</u> cm ²	6	575	#30
	7	1433	#34
(D) Double Section	8	93	120/44(D)

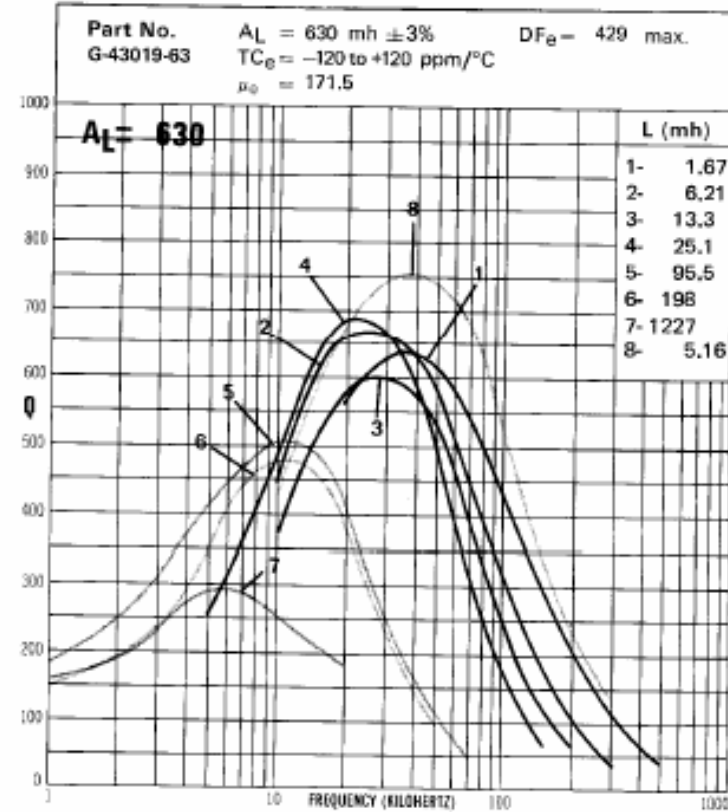
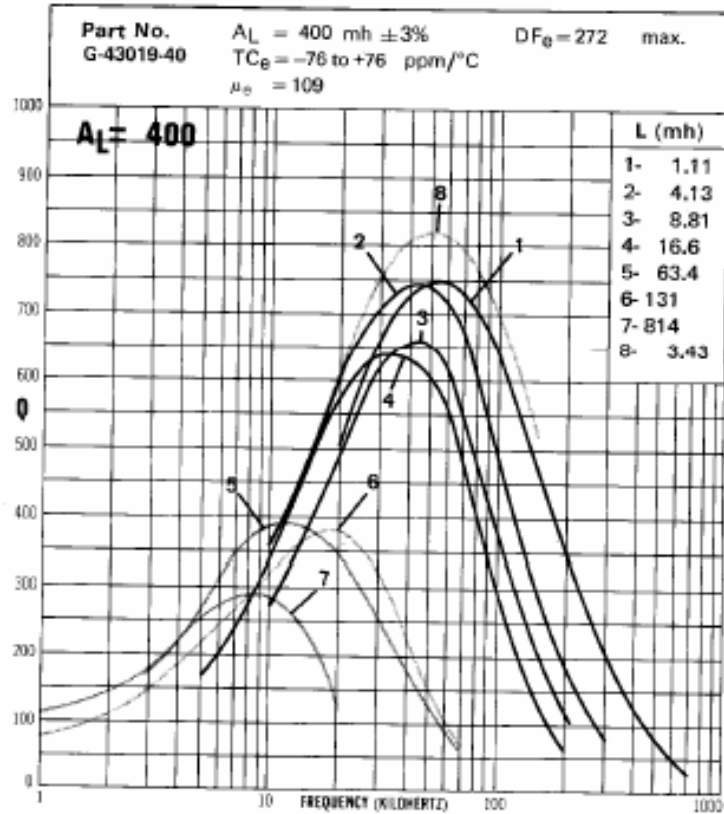

Fig 35

Core Size 36mm x 22mm Material G

All measurements made on single section bobbins except where noted.

BOBBIN WINDING AREA (Per Section)	BOBBIN INFORMATION		
	Number	Turns	Wire
Single Sect. <u>.755</u> cm ²	1	32	360/44
	2	72	180/44
	3	132	100/44
Double Sect. <u>.357</u> cm ²	4	200	72/44
	5	500	#28
Triple Sect. <u>.225</u> cm ²	6	1050	#32
	7	1775	#34
(D) Double Section	8	106	150/44(D)

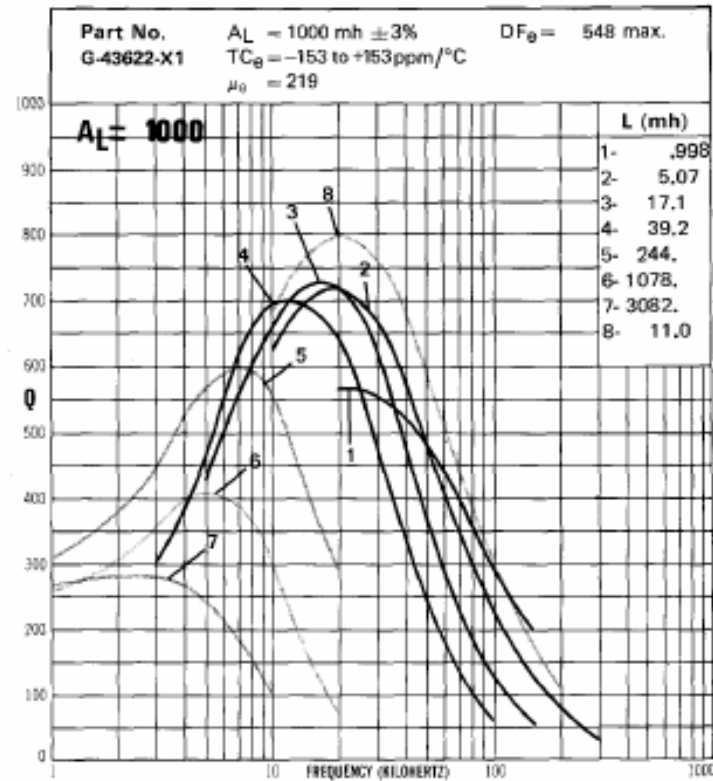
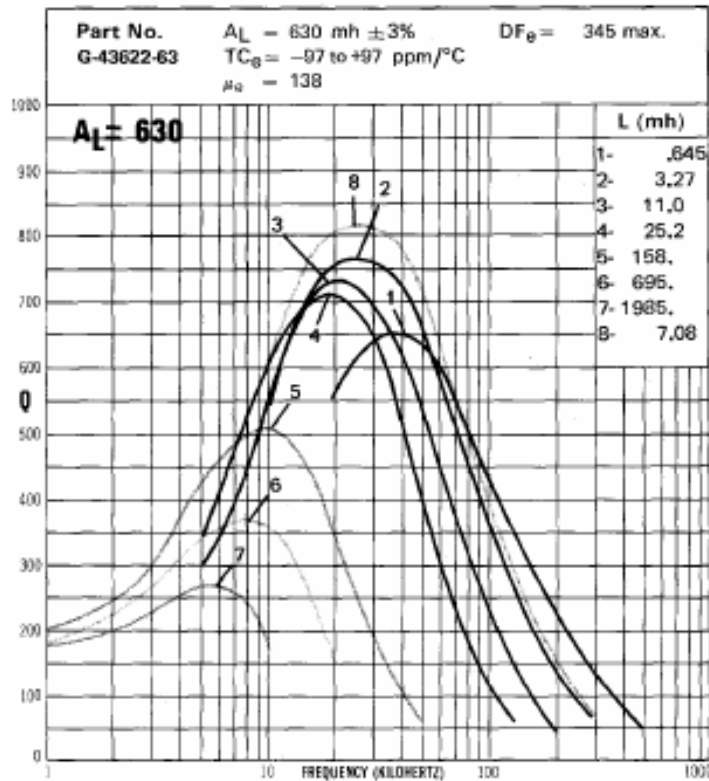

Fig 36

Air-Core Inductors

- Coils without a magnetic core are said to have an air core. Inductors of this form are useful for well above 10 MHz. Air has a μ of 1, will not saturate, and has no core losses, so the Q is almost strictly dependent upon the winding itself.
- For a single-layer solenoid wound on a nonmagnetic material such as ceramic or phenolic, the inductance in henrys can be approximated by:

$$L = N^2 \frac{r^2}{9r + 10l} \times 10^{-6} \quad (\text{equation 16})$$

where N is the number of turns, r is the radius (diameter/2), and l is the coil length, with r and l in inches.

- Air-core solenoid inductors have high leakage inductance, so they can be easily affected by nearby metallic surfaces.

A toroidal shape will have less leakage, since the magnetic field will be more contained. The equation for the inductance of an air-core toroid with a single-layer winding was given by equation 5 with $\mu = 1$.

$$L = \frac{4\pi N^2 \mu A}{mL} 10^{-9}$$

DESIGN OF TRANSFORMERS

- Figure 37 illustrates the linear equivalent circuit of a practical transformer. All of the parameters are reflected into the primary and followed by an ideal transformer having a turns ratio of 1:N.
- R_{DC+AC} is the secondary DC resistance reflected into the primary by $1/N^2$ plus the primary DC resistance, and the skin effect resistance R_{AC} . L_K is the leakage inductance which is the primary inductance seen with a short circuit on the secondary (with perfect coupling L_K would be 0). Capacitance C_d is the equivalent parallel distributed capacity. Inductance L_p is the primary inductance with the secondary open. R_p represents the parallel loss which is mainly core loss and dielectric loss. Finally this network is followed by an Ideal Transformer with a turns ratio of 1:N resulting in an impedance ratio of 1:N².

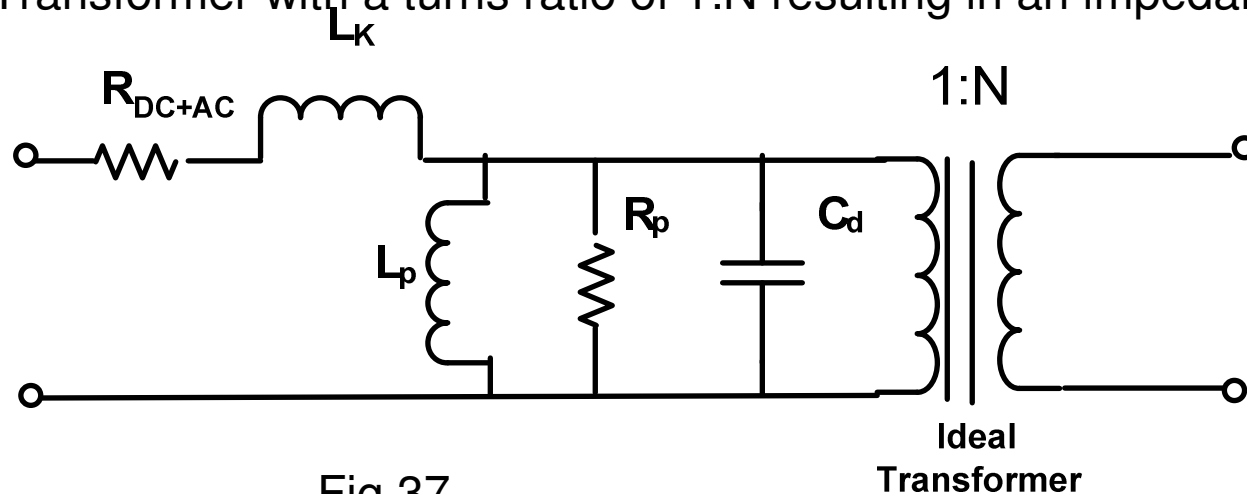

Fig 37

Ideal
Transformer

Low Frequency Equivalent Circuit

Let us assume the transformer is used in a circuit with a source resistance R_S and is terminated on the secondary with a load resistor R_L . Assuming R_S is much larger than R_{DC} we obtain figure 38 where the transformer reflects the secondary load resistor into the primary as R_L/N^2 .

Fig 38

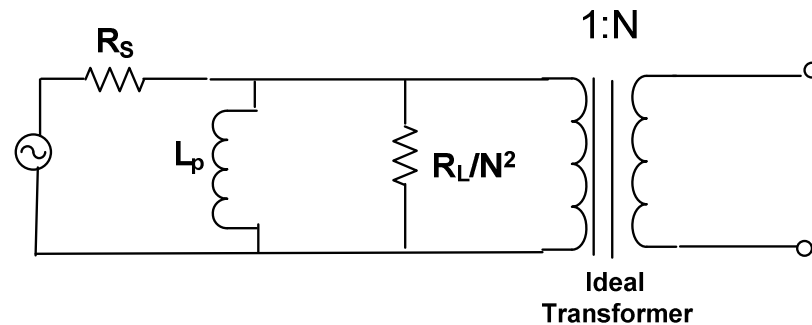

Since in the vast majority of applications the function of the transformer is to *match* two different impedances, we can obtain the following circuit where $R_S=R$ and R_L is reflected into the primary as R . Since an ideal transformer has infinite input impedance we can interpret this circuit as a *One-Pole High-Pass filter*.

Fig 39

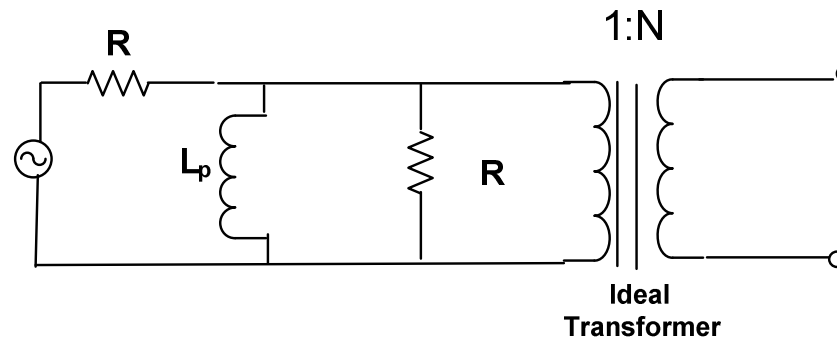

- The 3dB point of this high-pass filter is the point where the impedance of the inductor is equal to R/2 so:

$$\omega_{3dB}L=R/2$$

$$L=R/(4\pi F_{3dB})$$

Typically the lower edge attenuation of a transformer is specified not at 3dB but at a lesser attenuation. A wide band flat transformer may be specified for a low end attenuation of 0.25dB and so forth.

- In order to calculate a minimum inductance value so the low frequency end attenuation does not exceed X dB at F_L the 3dB point has to be below F_L .

- Using the graph of figure 40 , from the desired attenuation in dB at F_L determine K corresponding to that attenuation. F_{3dB} is then F_L/K . For example for 1dB of attenuation at 200Hz K=2 so the 3dB point must be 100Hz.

$$F_{3dB} = F_L / K \quad \text{Then } L = R / (4\pi F_{3dB}) \quad \text{(Equation 17)}$$

- This is the minimum inductance since a larger value will result in extending the low frequency end.

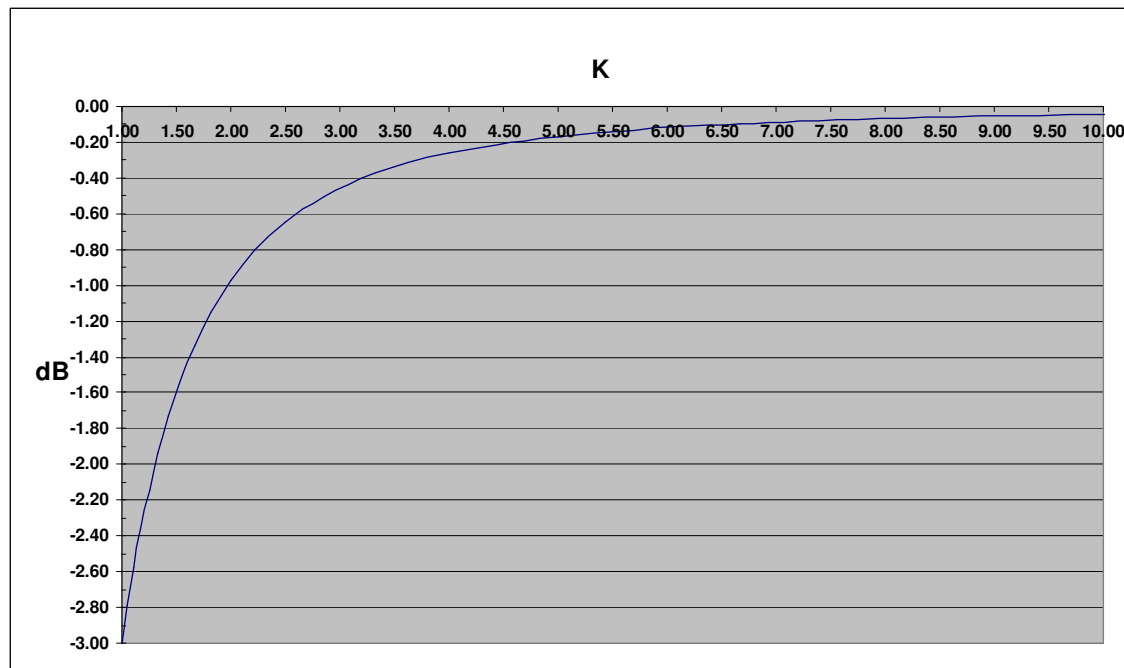

Fig 40

- Note that this is not the insertion loss of the transformer which can be defined as the flat loss, but this is the roll-off of the low frequency response from a reference in the flat region.
- In the following figure the Insertion Loss is the loss that occurs *relative to the transformer being ideal*, at a midpoint reference frequency F_{REF} .
- If the transformer does not have a 1:1 turns ratio the output must be calculated as if you had an ideal (lossless) transformer and the insertion loss is relative to that output.
- At F_L , the lower cut-off, the desired attenuation of XdB will occur *relative to the 0dB reference*.

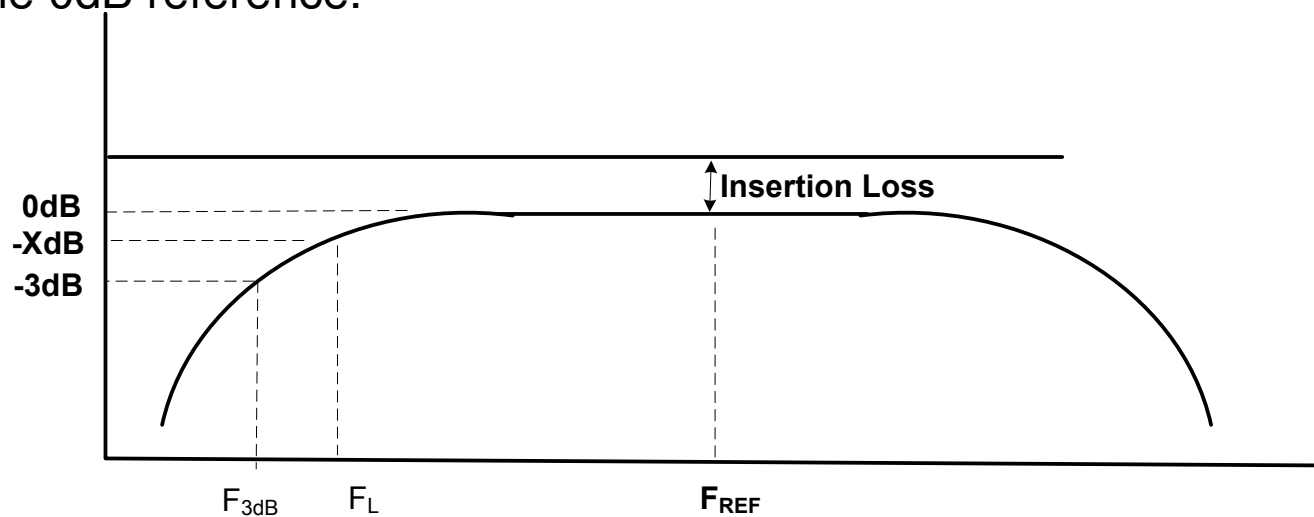

Fig 41

•Figure 42 illustrates the *high frequency equivalent circuit* of a transformer. The dominant components that limit the high frequency response are L_K the leakage inductance and C_d the distributed capacitance. These two components effectively create a two-pole low-pass filter. Also the increase in core and dielectric loss will lower R_p and skin effect will raise the AC component of R_{DC+AC} .

•The value of L_K is determined mainly by the winding method so better coupling (less leakage flux) between primary and secondary reduces L_K .

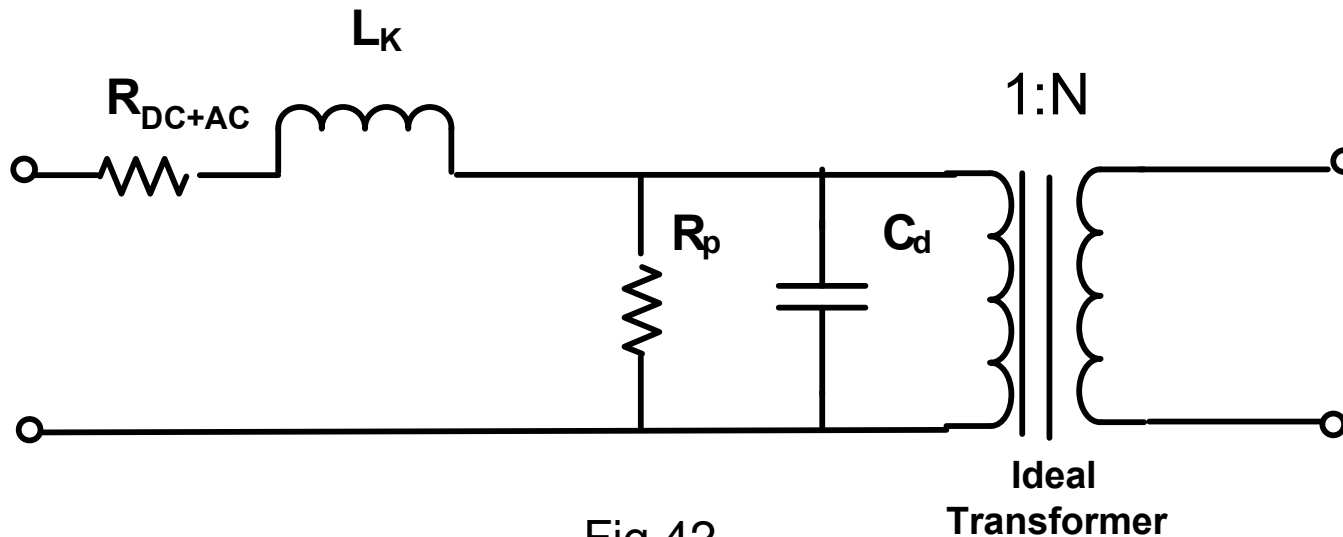

Fig 42

Ideal
Transformer

- The single most important factor in selecting the magnetic material is the inductance L_p determined by the low end cutoff frequency F_L . The material with the highest permeability at F_L should be the recommended choice providing that the core losses and permeability at the high frequency end do not degrade significantly. Trade-offs are always involved.
- For most ferrite broadband transformers the mid-band is affected mainly by the winding resistances (AC + DC).
- In the higher frequency region the leakage inductance and distributed capacitance are the limiting factors and are also quite difficult to estimate.
- To minimize leakage inductance the number of turns should be minimized which goes along with picking a high permeability material. Also the winding method should insure tight coupling between primary and secondary such as splitting the higher turn winding in half and surrounding the winding having the lesser turns. Also the higher the turns ratio the larger the equivalent leakage inductance reflected into the primary.
- To minimize distributed capacitance splitting up the winding using a split (multi-section) bobbin helps. Also Mylar tape a few mils thick between windings helps keep the capacitance down.
- Which ever core geometry is selected there should be no air gap. Care should be taken that if two cores have to be attached to each other no adhesive should be present on the core surfaces that make contact with each other, as that would introduce a gap.

Bifilar Windings

- If a transformer has a 1:1 turns ratio resulting from equal source and load impedances, the best magnetic coupling between windings would occur if both windings were *physically in the same location*. This of course can not occur but a bifilar winding would come closest. An example of this on a toroid is shown in the following illustration:



Fig 43

- The negative of a bifilar winding is that higher distributed capacitance will occur. As is sometimes the rule rather than the exception some trial and error will be needed until one obtains the best compromise during transformer design.

Magnetic Core Selection for Transformers

- Selecting the proper geometry and core material are critical decisions to insure a successful design.
- The first step is to calculate the minimum primary inductance L_p which is determined from the lower 3dB point as previously shown.
- A variety of core materials and geometries are used for transformers. For very low frequencies such as a few hertz, transformers using laminations are the best choice since they offer extremely high permeability (over 100,000). Laminations are made of a very high permeability material.
- The structure consists of interleaved E or F shaped thin pieces of a high permeability metal (MuMetal for example) inserted into a nylon bobbin as shown in figure 44. However for increased frequencies, the losses in the laminations become unacceptable (eddy currents etc.). The thinner the lamination the less the higher frequency loss.

Fig 44

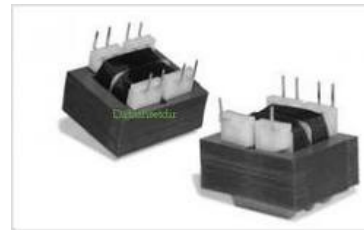
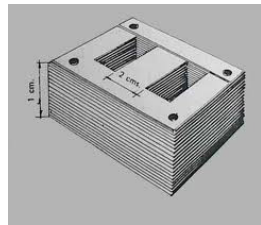

- With the advent of high permeability ferrites (although not in the 100,000 range) the use of this geometry is very limited except for power transformers (which do not involve high permeability materials). Ferrite cores represent the preferred approach for the design of wideband transformers ranging from a few hundred Hertz to 1 or 2 MHz .
- Ferrite cores come in a wide variety of shapes and sizes as shown in figure 45. For a transformer design you want to obtain the maximum permeability over the operating frequency range resulting in the least number of turns once a material is chosen. The structure should then have no gap (assuming no DC current is present). The bobbin should be as fully enclosed magnetically as is practical.



Fig 45

BROADBAND TRANSFORMER DESIGN USING EP CORES

It must be mentioned that although this section emphasizes the design of a transformer using EP cores, much of the material is applicable to transformer design in general using other core structures.

- EP type cores are most popular for the design of broadband transformers not extending into higher frequencies over a few MHz. They have become more popular than pot cores so their use will be emphasized in this section.
- EP cores have a round center-post and a cubical shape which encloses the coil completely except for the printed circuit board terminals extending from the bobbin.
- This particular shape minimizes the effect of any air gaps formed at the mating surfaces in the magnetic path and provides excellent shielding.
- The EP shape is very efficient and results in a large ratio of volume to total space used. Printed circuit hardware such as bobbins containing PC pins, multi-section bobbins and metal clamps are readily available.

- EP cores come in six basic sizes: EP5, EP7, EP10, EP13, EP17 and EP20. The following is an exploded view of an EP core and bobbin. An outside mounting clamp is also shown below to provide sufficient pressure to maintain a gapless structure. Alternately the core halves can be glued together using an adhesive on the outside surface *being careful not to get any adhesive on the mating surfaces.*

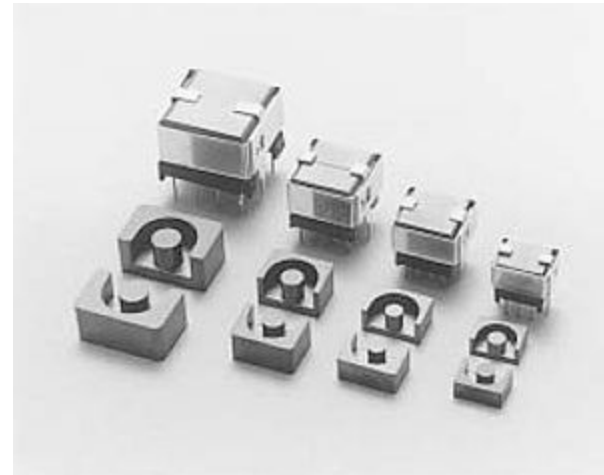
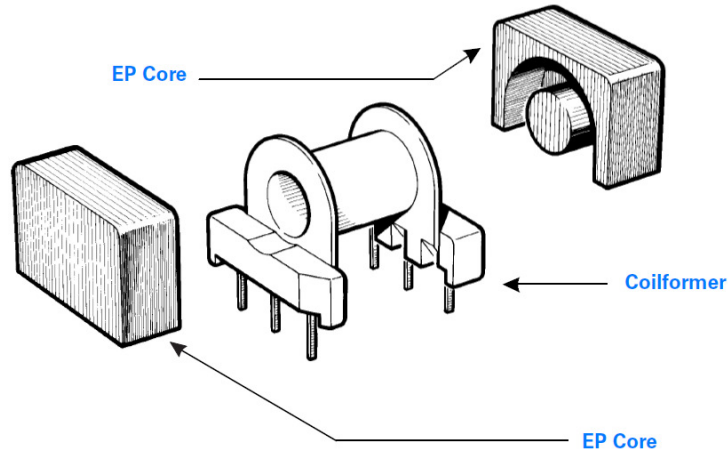
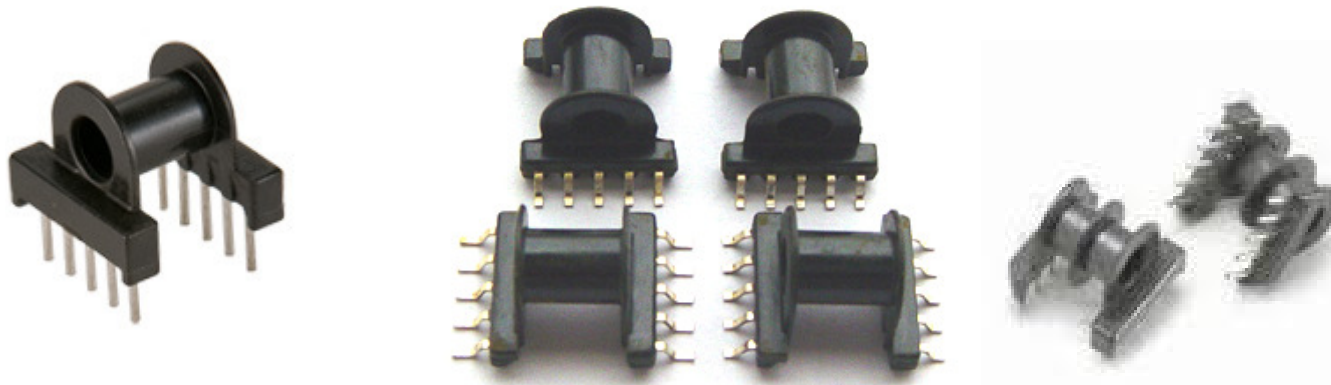

Fig 46

- Bobbins come in a variety of structures such as single section, multiple section, PC pins, surface mount pins etc.



- Magnetics Inc provides EP cores in a variety of different ferrite materials. Not all sizes are available in all materials.

- Note that other manufacturers will provide EP cores in other permeabilities which will have different characteristics so the use of Magnetics Inc. EP cores is only shown as an illustrative example. Observe from the following curves that higher Permeability materials tend to roll off in permeability at lower frequencies.

Magnetics Inc. Material Designation

Fig 47

			R	P	F	J	W
Initial Permeability	μ_i	—	2,300 \pm 25%	2,500 \pm 25%	3,000 \pm 20%	5,000 \pm 20%	10,000 \pm 30%
Maximum Usable Frequency (50% roll-off)	f	MHz	<1.5	<1.2	<1.3	<1	<0.25

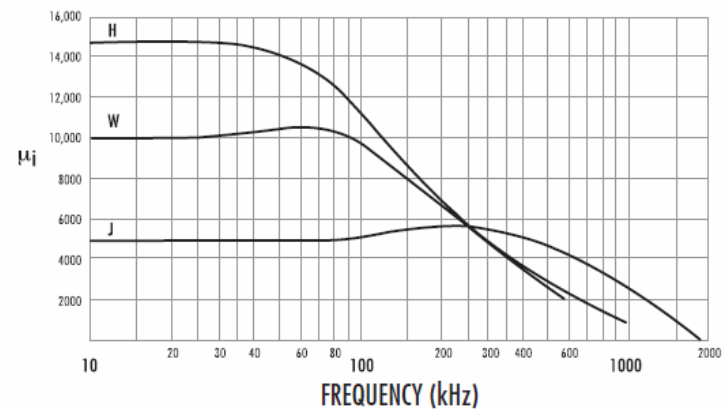
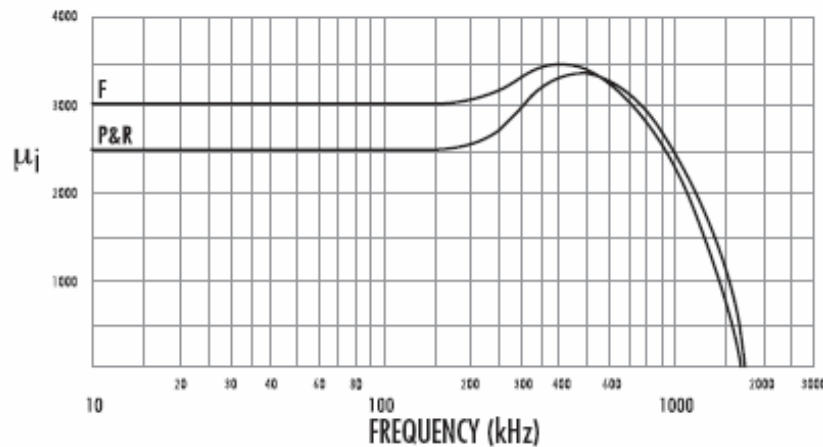

•The following chart indicates the dimensions of each half of a gapless EP core.

•The assembled core must be gapless. The center leg mating surfaces must be clean and in contact with each other before application of the mounting clamp. No adhesive should be present on any of the mating surfaces. Dimensions are as follows:

Fig 48

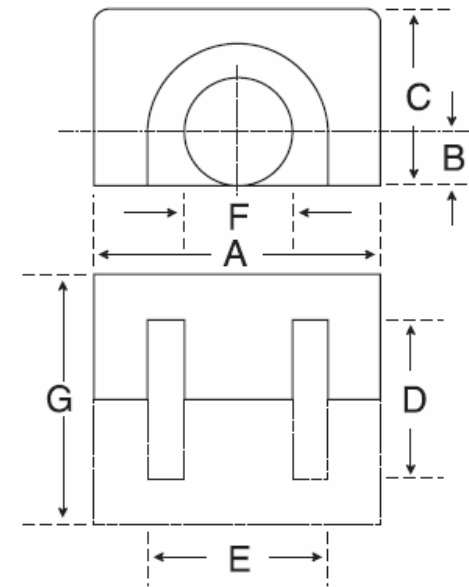

CORE SIZE	A mm	A inches	B mm	B inches	Cmm	C inches	D mm	D inches	E mm	E inches	F mm	F inches	G mm	G inches	Ae (effective area mm ²)
EP7	9.20	0.36	1.70	0.07	6.35	0.25	5.20	0.20	7.40	0.29	3.30	0.13	7.40	0.29	10.7
EP10	11.50	0.45	1.85	0.07	7.65	0.30	7.40	0.29	9.40	0.37	3.30	0.13	10.30	0.41	11.3
EP13	12.50	0.49	2.40	0.09	8.80	0.35	9.20	0.36	10.00	0.39	4.35	0.17	12.85	0.51	19.5
EP17	18.00	0.71	3.25	0.13	11.00	0.43	11.50	0.45	11.75	0.46	5.65	0.22	16.80	0.66	33.7
EP20	24.00	0.95	4.50	0.18	15.05	0.59	14.30	0.56	16.50	0.65	8.75	0.34	21.40	0.84	78.7

For some applications such as when a DC current is present, high AC excitation, or very high linearity is desired, a small gap will tend to linearize the transformers' behavior. Some EP cores from some manufacturers are available with an air gap which of course will reduce the A_L (mH/1000 turns).

The following table provides the A_L in mH/1000 turns for the standard core sizes in Magnetics Inc. Materials.

Table 13

Minimum A_L /1000 turns for Different Core Sizes of EP Cores								
		<u>Material</u>						
<u>Size</u>		<u>K</u>	<u>R</u>	<u>P</u>	<u>F</u>	<u>J</u>	<u>W</u>	
EP7		570	810	880	1,240 +/-25%	1,930	3,600	
EP10		550	780	850	1,200 +/- 25%	1,850	3,360	
EP13		810	1,150	1,250	2,000 +/-25%	2,800	5,000	
EP17		1,250	1,790	1,950	3,100 +/-25%	4,400	8,000	
EP20		2,200	3,170	3,450	5,000 +/- 20%	7,200	13,500	

Once a primary inductance is chosen, a core and material selected, and the number of turns calculated, the secondary turns need to be calculated based on the turns ratio which is the square-root of the secondary to primary impedance Ratio. R_{prim} is the source impedance seen by the primary. R_{sec} is the load impedance seen by the secondary. The function of the transformer is to match the source and load impedance. Note that the terms “R” and “Impedance” are used interchangeably since we are assuming we are dealing with resistive terminations.

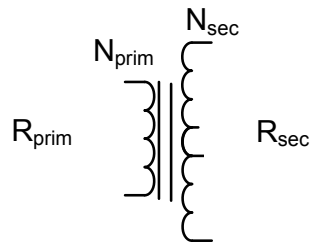

$$\frac{N_{\text{sec}}}{N_{\text{pri}}} = \sqrt{\frac{R_{\text{sec}}}{R_{\text{pri}}}} \quad (\text{Equation 17})$$

Fig 49

- Once the number of turns for both primary and secondary are computed, the wire sizes and winding methods need to be determined. *Unlike the design of an inductor or a passive filter it is rare that optimum performance is obtained during the first cut for a difficult transformer. This is because of the interaction of additional parasitic components.*

- Although the low frequency response is highly predictable given the inductance of the primary, the high frequency end is much less predictable due to leakage inductance and stray capacitance not only from the primary winding but also reflected from the secondary, and capacitance to the core and between windings

- For maximum efficiency it is best to allocate the same cross-sectional area of copper to each winding although this rule is mostly applicable to higher power transformers. (This presentation is geared more towards signal transformers.)
So if the primary is lets say 100 turns and the secondary is 1,000 turns, the wire sizes for the two windings will not be equal. The 1,000 turn winding will use a wire gauge that has 1/10 the cross sectional area of the 100 turn winding. Also for maximum efficiency the bobbin should be full.

- However for designs having a low frequency end of 100KHz to 1MHz this is less important as because of skin effect, the current will travel on the outside surface of the wire. Litz wire can help efficiency but the added capacitance due to the increased surface area will affect the high frequency response.

The following chart provides the maximum number of turns for each Core size for a range of wire sizes. If a multi-section bobbin is used at least one wire size should be reduced.

Wire Capacities of Standard PC Bobbins for EP Cores					
Wire Size	EP7	EP10	EP13	EP17	EP20
20					
21					
22					
23					63
24					80
25				55	100
26				69	127
27		65	78	87	158
28		82	99	110	203
29		102	124	137	253
30		130	157	176	317
31	61	162	196	220	399
32	77	207	251	275	507
33	97	259	314	346	634
34	123	324	392	440	798
35	153	408	494	550	1,006
36	196	518	627	693	1,267
37	245	648	784	873	1,597
38	306	816	988	1,099	2,012
39	386	1,029	1,245	1,385	2,534
40	490	1,295	1,568	1,746	3,193
41	613	1,632	1,976	2,199	4,025
42	772	2,057	2,490	2,771	5,069
43	973	2,591	3,136	3,492	6,389
44	1,226	3,265	3,952	4,398	8,050
45	1,545	4,114	4,981	5,543	10,137

Table 14

- Let us now go through an example of designing a transformer using a EP core. *Note that a similar procedure can be used for other core geometries such as a toroid or a pot core as long as the magnetic parameters are appropriate for the requirement.*

Required:

Match a primary source resistance of 100Ω to a secondary load of 600Ω . The frequency band of operation should be from 10KHz to 100KHz with less than a 3dB roll-off at the extremes. Signal levels do not exceed $10V_{\text{rms}}$ and no DC is present.

Results:

First determine the primary inductance.

Since the lower cut-off F_L is 10KHz, and $<3\text{dB}$ is required at this frequency, let us pick an inductance for the roll-off at 10KHz to be 1dB to allow some margin.

Using figure 40, for 1dB $K=2.0$, so using equation 16

$$F_{3\text{db}} = F_L / K = 5\text{KHz}$$

$$\text{Then } L = R / (4\pi F_{3\text{dB}}) = L = 100 / (4\pi 5,000) = 1.59\text{mH}$$

Next select a core geometry, size and material

For the purposes of this design let us select an EP core geometry. This example is illustrative so we could have selected other geometries such as a Pot Core or a Toroid.

Let us choose an EP17 size. Figure 47 indicates the Magnetics Inc. F material has a high permeability ($\cong 3,000$) which is still flat in the 100KHz region. The dimensions are given in figure 48.

Calculate the primary and secondary turns

Table 13 indicates that the $A_L/1000$ turns for the EP17 in F material is 3,100mH.

Equation 14 indicates that given $A_L = \text{mH}/1,000 \text{ Turns}$ $N = 10^3 \sqrt{\frac{L}{A_L}}$

So for 1.59mH $N_{\text{pri}} = 22.6$ turns, so lets round it upwards to 23 turns.

So using equation 17: $\frac{N_{\text{sec}}}{N_{\text{pri}}} = \sqrt{\frac{600 \Omega}{100 \Omega}} = 2.449$

The secondary turns $N_{\text{sec}} = 23 \times 2.449 = 56.3$ so we will use 56 turns

Figure 50
 Resulting Transformer
 EP17 Core Magnetics F Material

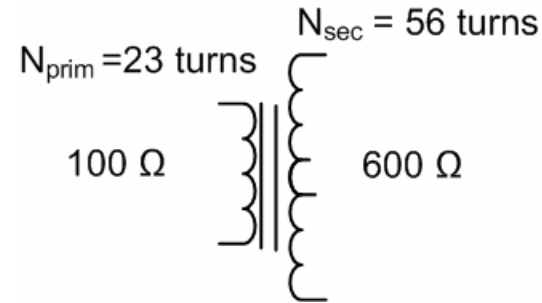

Let us now compute the wire sizes using table 14. To keep the cross sectional area of both windings the same:

a) First double the higher turn winding

112 turns requires 28awg for a full bobbin

So if we use 28awg for the 56 turns of the secondary this leaves 56 turns of 28awg left over.

b) Next we need to compute the wire size for the 23 turns to have the equivalent cross sectional area using the relationship between wire sizes.

56 turns 28awg

28 turns 25awg (3 wire sizes 2x cross sectional area so use $\frac{1}{2}$ turns)

22 turns 24awg (1 wire size is 1.26 cross sectional area so use $1/1.26$ turns)

That's close enough to 23 turns so we will use 24awg for the primary.

Figure 51 Final Design
EP17 Core Magnetics F Material

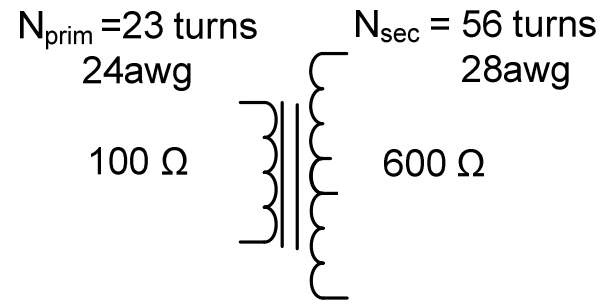

Let us do a sanity check to make sure the core wont saturate.

Equation 6 was given as follows where B is the maximum flux density in Gauss, N is the number of turns, f is the frequency in Hertz, and A is the cross-sectional area of the core in square centimeters.

$$E_{\text{rms}} = 4.44BNfA \times 10^{-8}$$

:

$$\text{So } B = E_{\text{rms}} / (4.44NfA \times 10^{-8})$$

With $10V_{\text{rms}}$ applied to the primary at 10KHz (lowest frequency) and the effective cross-sectional area from figure 48 is 33.7 (Ae) The flux density B is 29 gauss. This is a very comfortable number so no core saturation will occur.

- The final issue is to choose the winding method. For best coupling (least leakage inductance) the lesser turn winding should be put on first. This is then followed by the winding having more turns.
- Typically polyurethane insulated wire can support about $500V_{\text{rms}}$ breakdown so no insulation might be necessary between windings. However to insure no breakdown will occur a layer of Mylar tape is generally used using a rule of thumb of 500V breakdown per mil of tape thickness. The negative is that the leakage inductance will increase as the coupling is reduced.
- Finally if leakage inductance is an issue in a design, the higher turn winding can be split in half with the lower turn winding sandwiched between both halves of the higher turn winding. The inside and outside windings are to be in series.

- A higher frequency version of this transformer could have been designed using a powdered iron core toroid. The same sequence could have been followed. The only difference would have been winding method. For few turns (typically less than 50 turns) a single layer approach could have been used where the smaller turn winding is put on first and the secondary wound over it, also single layer.
- Finally for a lower frequency transformer a MPP toroid could have been used although the cost would have been higher.

- Figure 52 shows a common application of a transformer used as a common-mode choke.

The differential impedance *added* by the common-mode choke is very low since a differential signal will produce *opposing* magnetic fields which would Cancel (The dot represents the “Start” of each winding and hence shows polarity.) So the common-mode choke would pass the differential signal almost unaffected. For best common-mode rejection a bifilar winding method would be best but the high inter-winding capacity could limit bandwidth.

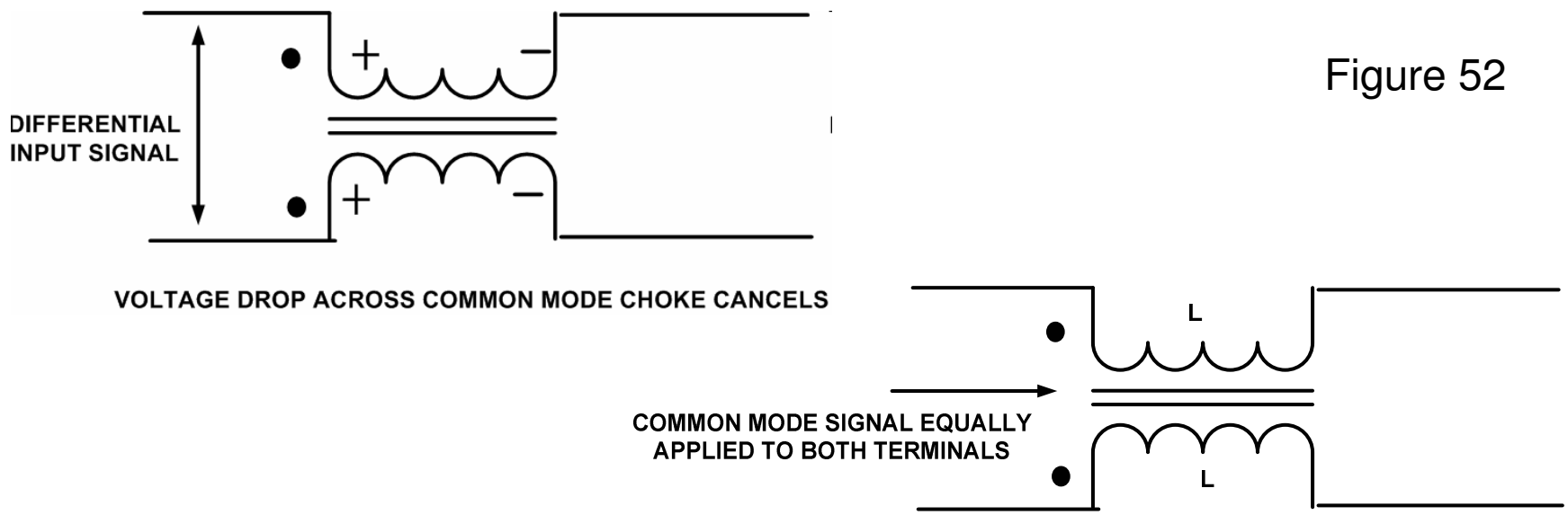

The common mode impedance to a signal applied *equally* to both starts would be high and a function of the inductance, so common-mode noise would be reduced.

Tapped Inductor

- When a coil includes a tap, a coefficient of magnetic coupling near unity is desirable to avoid leakage inductance.
- For a toroid The 360° winding method will have a typical coefficient of coupling of about 0.99 for permeabilities of 125 and higher. A two-section winding has a coefficient of coupling near 0.8. The four-section and progressive (or single layer) winding methods result in coupling coefficients of approximately 0.3, which is unacceptable.
- A compromise for toroids involves applying the turns up to the tap in a straight-progressive or single layer fashion over the *total* core. The remaining turns are then distributed completely over the initial winding, also using the straight-progressive method (or single layer over single layer where applicable).

Figure 53

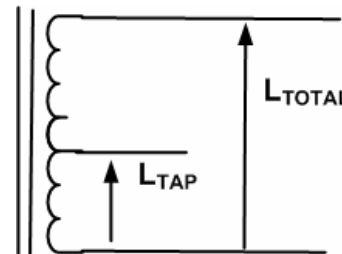

- The basic principles apply to any winding structure, Pot Core, RM Core etc. To obtain good coupling, the portion of the winding up to the tap should be in close proximity to the remainder of the winding. However, this results in higher distributed capacity, so a compromise may be desirable.
- Higher core permeability will increase the coupling but can sometimes result in excessive core loss. The higher the ratio of overall to tap inductance, the lower the corresponding coefficient of coupling so the higher the leakage inductance. Inductance ratios of 25 or more should be avoided if possible.
- A special case of a tapped inductor is one having a center-tap. In many cases center tap accuracy is extremely critical. The solution would be to wind the coil bi-filar using half the number of turns and then put both windings in series. For example if 100 turns are required, use 50 turns bi-filar and connect the two windings in series. The junction of the two coils is a very precise center tap. This would also apply for a transformer winding. The negative is a higher distributed capacitance.
- Figure 54 illustrates how a center-tap can be created from a bi-filar winding on a toroid.

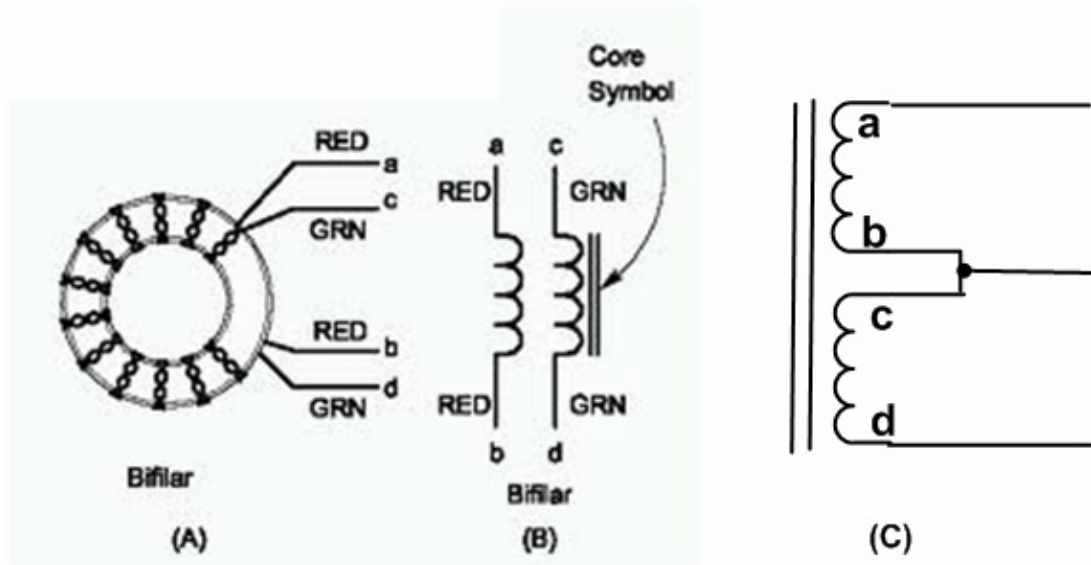
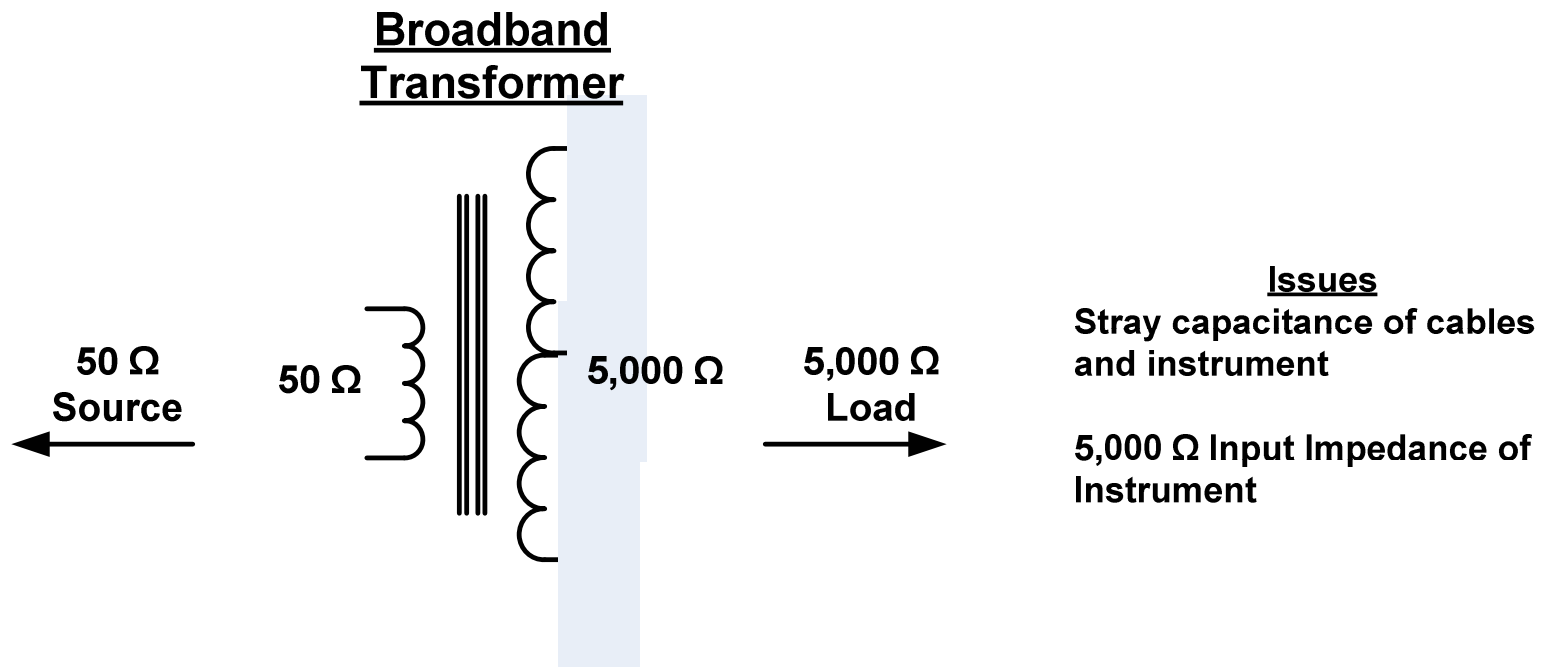
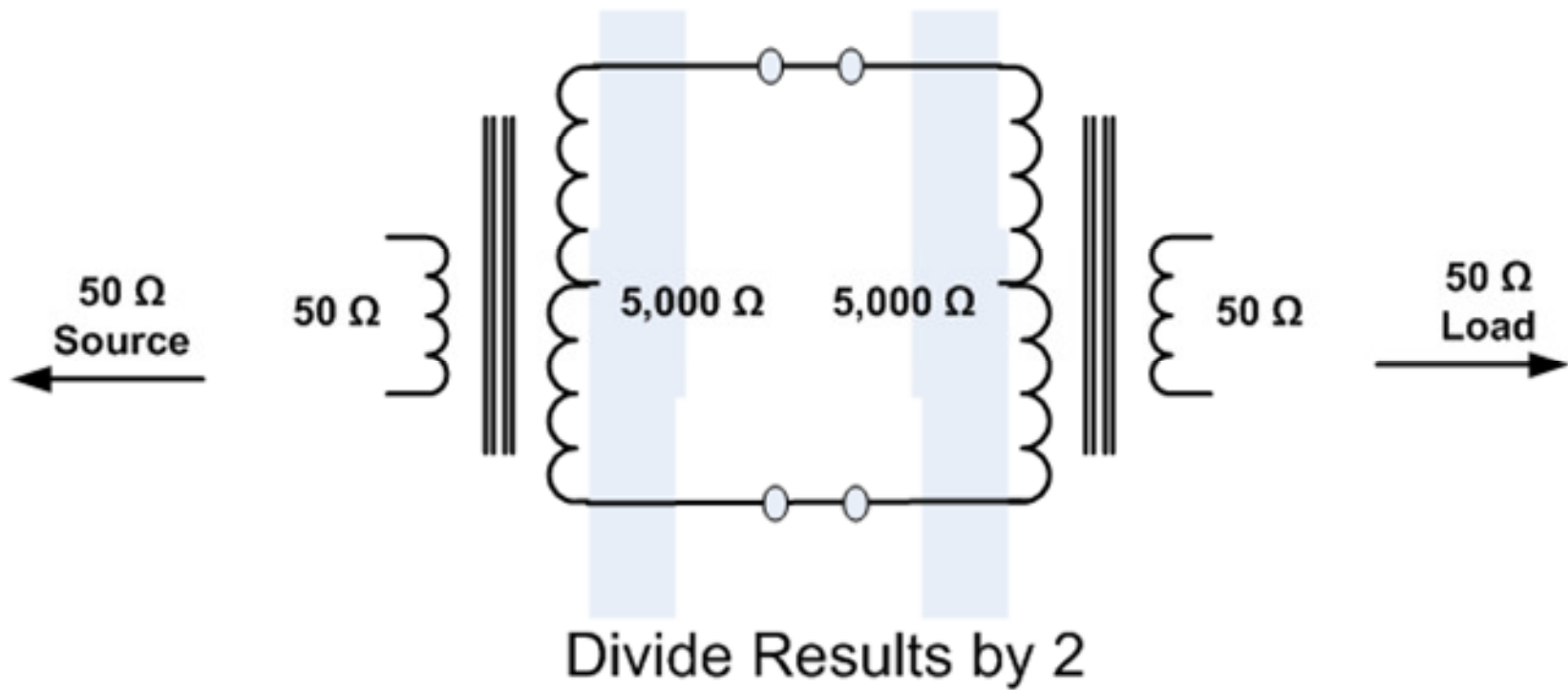

Figure 54

MEASUREMENT PROBLEM



SOLUTION



REFERENCES

Magnetics Inc.
110 Delta Drive
Pittsburgh, PA 15238-0428
Headquarters: 1-412-963-9363
Sales: 1-412-696-1333
Technology Center: 1-412-963-5500

<http://www.mag-inc.com/>

Magnetics Inc. is a major provider of MPP toroids, ferrite pot cores, EP cores and many other ferrite geometries as well as mounting hardware. The above URL will lead you to a number of links which provide technical data on the various cores as well as a significant amount of tutorial information.

- 2011 Powder Core Catalog
- A Critical Comparison of Ferrites with Other Magnetic Materials
- Standard Q Curves for A,D and G Materials

Ferroxcube Inc. (Division of Yaego)
US Regional Office
12280 Rojas Dr # C
El Paso, TX 79936-7749
(915) 599 2328

<http://www.ferroxcube.com/>

Ferroxcube was originally a Dutch company (Phillips) and pioneered magnetics using ferrites along with Magnetics Inc. Some of the more useful documents available from Ferroxcube are:

- Ferroxcube Data Handbook 2009
- Product Selection guide 2003
- Application Note - The Use of Ferrite Cores in DSL Wideband Transformers

Micrometals Inc.
5615 E. La Palma Ave
Anaheim, CA 92807
714 970-9400

<http://www.micrometals.com/>

Micrometals has been a major supplier of iron powder cores in a variety of forms since 1951.

- Calculating the High Frequency Resistance of Single and Double layer Toroidal Windings
- Design guidelines for Iron Powder Cores
- Iron Power Cores for High Q Inductors
- RF Applications Issue H December 2005
- Calculating the High Frequency Response of Single and Double Layer Toroidal Windings
- Practical Construction Tips for Coils Using Iron Powder Cores

Amidon Inc.
240 Briggs Ave
Costa Mesa, CA 92626
800-898-1883

<https://www.amidoncorp.com/>

Amidon is a manufacturer of Ferrite Toroids, Iron Powder Toroids and other geometries for various markets including HAM radio. They are also a Distributor of magnetics products.

- Amidon Technical Data Book 2000 Edition

FAIR-RITE Products Inc

1 Commercial Row

Wallkill, NY 12589

845-895-2055

<http://www.fair-rite.com/>

Fair-Rite is a major supplier of ferrites in many forms

Use of Ferrites in Broadband Transformers

TDK U.S.A.

525 RXR Plaza

Uniondale, NY 11556

Phone: (516) 535-2600

<http://www.tdk.com/ferrites.php/>

Ferrite for Telecommunication EP Cores April 2011

Ferrite for Telecommunication Pot Cores April 2011

Ferrite for Telecommunications Summary April 2011

Electronic Filter Design Handbook-Fourth Edition

Arthur Williams and Dr. Fred Taylor

McGraw Hill Publishers

<http://www.amazon.com/Electronic-Filter-Handbook-McGraw-Hill-Handbooks/>

Long-established as “The Bible” of practical electronic filter design, McGraw-Hill's classic Electronic Filter Design Handbook has been completely revised and updated for a new generation of design engineers. The Fourth Edition includes the most recent advances in both analog and digital filter design plus a CD for simplifying the design process, ensuring accuracy of design, and saving hours of manual computation. In addition to LC and Active filters a wide range of other topics are covered such as power splitters, magnetic circuit design and Introduction to Microwave filters.

Arthur Williams

abw0628@optonline.net